

## Design and Manufacture of Bushings for Glass Fibre Production

by

Michael Koch and David Lupton

W. C. Heraeus GmbH  
Engineered Materials Division  
Heraeusstrasse 12-14  
63450 Hanau, Germany

Paper presented at HVG-Colloquium  
“Production, Properties and Applications  
of Refractory and Platinum Group Metals for the  
Contact with Glass Melts”  
held at the **glasstec 2006**  
Düsseldorf  
24<sup>th</sup> October 2006

Proceedings published by HVG Hüttentechnische Vereinigung der Deutschen  
Glasindustrie, Siemensstrasse 45, 63071 Offenbach am Main, Germany

## **Design and Manufacture of Bushings for Glass Fibre Production**

by

Michael Koch and David Lupton

W. C. Heraeus GmbH

Engineered Materials Division

Heraeusstrasse 12-14

63450 Hanau

Germany

### **Historical**

The method of making glass fibres by means of a bushing was first demonstrated in 1908 by W. von Paczinsky in Hamburg, although a British silk weaver made a glass fabric in 1842, and another inventor, Edward Libbey, exhibited a dress woven of glass at the 1893 Columbian Exposition in Chicago. The manufacture of textile glass fibres using the technique of drawing the fibres through very fine orifices was developed in the 1930s in the USA and started in Germany in 1939. A useful summary of the manufacture and use of glass fibres is given in [1]. Further details are to be found for example in [2 and 3].

The earliest bushings used for industrial fibre production had 51 individual nozzles or “tips”. As production processes became more stable, this was increased to 102 and then 204 tips. In these early bushings, the tips were arranged in one or more long rows. Current bushings have up to 4000 tips and there is a trend to even larger numbers. In the most commonly used designs, the tips are arranged in double rows at right angles to the longitudinal axis of the bushing.

Although bushings have been manufactured from a wide range of materials in the course of development, alloys of platinum with rhodium have proved to be the optimum choice because of their unique combination of high temperature strength with excellent resistance to oxidation by the surrounding air and corrosion resistance to the molten glass. Heraeus has been manufacturing bushings for textile glass fibre production since 1970.

### **What are glass fibre bushings and how do they work?**

Bushings are, in their simplest form, boxes made from platinum alloys and having a large number of small nozzles or tips on their underside. Typically, the tips have an internal diameter between 1.5 and 4 mm. The bushing is fixed in place by means of insulating refractory cement and is maintained at the operating temperature by direct resistance heating. Glass is maintained in a molten state with closely controlled viscosity inside the bushing and flows slowly through the tips under the influence of gravity. It is, of course, essential that the temperature over the whole of the bushing

base-plate or “tip-plate” is very uniform to ensure that the flow-rate of the glass and thus the final filament diameter is also uniform within narrow limits.

The glass emerging from the tips is drawn mechanically downwards at a speed of up to about a thousand metres per minute to give very fine filaments with diameters as small as 6  $\mu\text{m}$ , Figure 1a. The diagram in Figure 1b shows the essential parameters in the formation of a filament along the z-axis from a bushing tip of radius R.  $\Theta$  is the angle between the tangent to the glass meniscus and the z-axis.

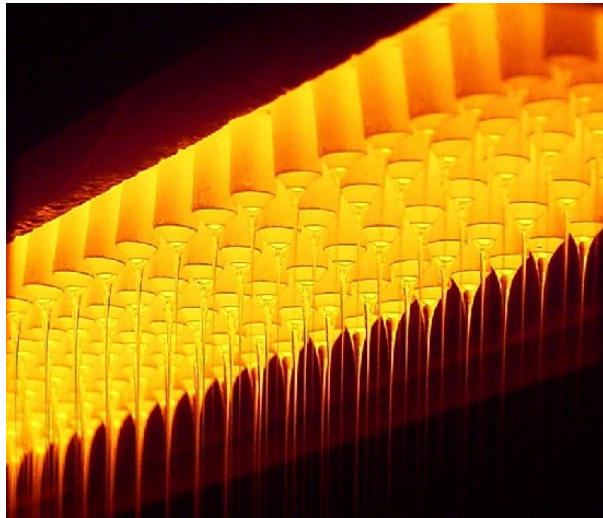

Figure 1a: Bushing in service.

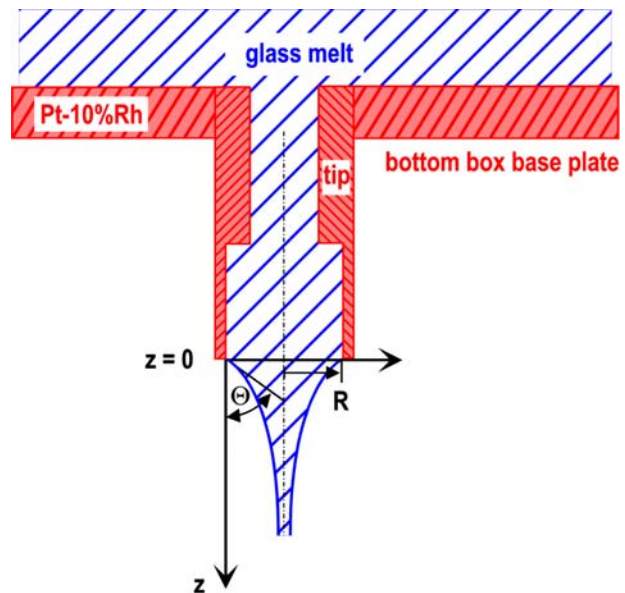

Figure 1b: Filament formation at tip.

**Figure 1:** Glass fibres forming at the tips of a bushing.

For the production of continuous fibres, the filaments run from the bushing to a common collecting point where size is applied and they are subsequently brought together as bundles or “strands” on a high speed winder.[4] In special cases, the filaments are drawn by high-speed flowing air which, of course, produces a mat of fibres.

There are two fundamentally different methods used for manufacturing glass fibres with bushings, i.e. the indirect or “marble” melt process and the direct melt process, Figures 2a and 2b.

### ***Indirect or “marble” melt process***

The bushing is fed with pellets or marbles of solid glass which have been manufactured in a separate process. The marbles are charged onto a horizontal perforated sheet where the glass melts and flows through the perforations into the lower chamber of the bushing. The tip-plate is typically about 20-50 mm below the perforated sheet. Although the melting and fiberising processes are essentially independent, it is essential that the level of glass in this lower chamber is kept

constant, i.e. the rate of glass melting on the perforated sheet must closely match the rate of fibre drawing. This is achieved by careful temperature control both in the design and the operation of the bushing.

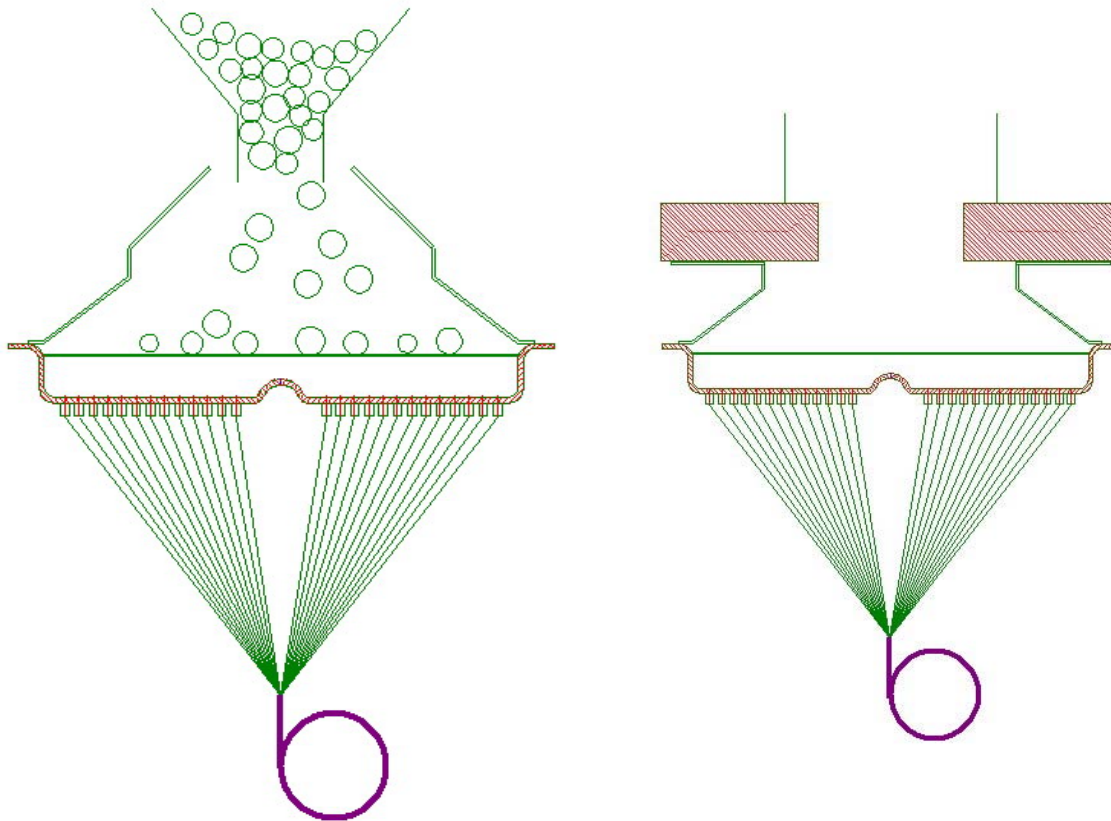

Figure 2a: Indirect or marble bushing.

Figure 2b: Direct melt bushing.

**Figure 2:** Operating principle of bushings for indirect and direct melt processes.

### ***Direct melt process***

This single-stage process is now the most widely used method for the production of textile glass fibres. A number of bushings are fed with molten glass directly from a central melting furnace or “tank” via a channel or “forehearth”. The glass flows into the bushing through a finely perforated sheet which serves mainly to homogenise the temperature distribution in the molten glass. The fibres are again drawn through the tips in the tip-plate of the bushing.

### **Methods for manufacturing glass fibre bushings**

Heraeus has two basic techniques for manufacturing the tip-plates of bushings. In the first process, the tips are cut from seamless drawn platinum alloy tubes which are then inserted into a plate with pre-punched holes and welded into position. With the second technique, a thicker sheet is used and the tips are pressed from this sheet by

a type of deep-drawing operation. The upper side of the tip-plate and the lower ends of the tips are then precision machined to meet final tolerances.

### ***Welded tips***

The main advantage of bushings with welded tips is that no special tooling is needed, Figures 3a and 3b. The manufacturing process is therefore very flexible, especially for small batch sizes. The layout of the tips in the tip-plate – in particular the diameters of the tips and the gaps between them – can be selected entirely to meet the requirements of the fibre drawing process without regard to the complexities of metal forming operations. It is also possible to position the tips closer together than with the pressed tips. A further advantage is the feasibility of using different materials for the tip-plate and the tips.

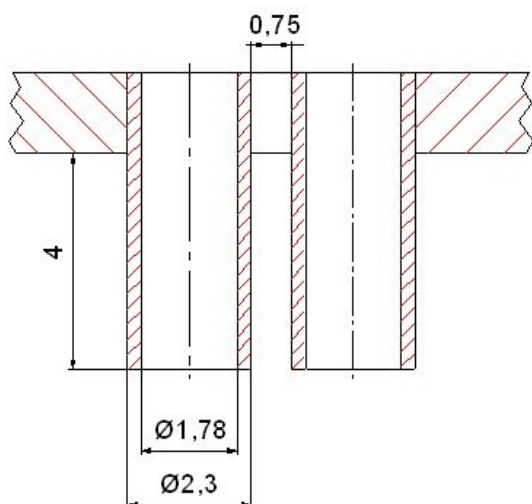

Figure 3a: Schematic design.

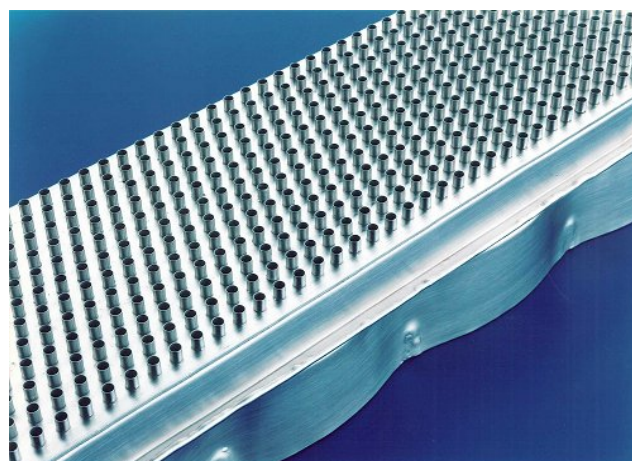

Figure 3b: Typical example.

**Figure 3:** Bushing with welded tips.

A potential disadvantage of bushings with welded tips is the risk of leaks at the weld joints. It is essential to use a thoroughly qualified welding process and to carry out detailed visual and dye-penetration inspections before releasing the bushing. Heraeus has found that manual TIG welding offers the most reliable results, but some manufacturers use laser welding and other techniques.

### ***Pressed tips***

The main advantage of tip-plates with pressed tips is the good mechanical stability resulting from the monolithic design and the tapered, conical form of the tips, Figures 4a and 4b. Additionally, the tip-plate is free from any weld seams through its thickness.

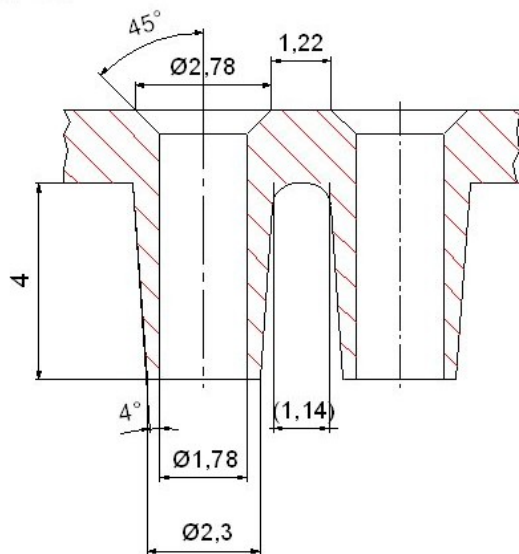

Figure 4a: Schematic design.

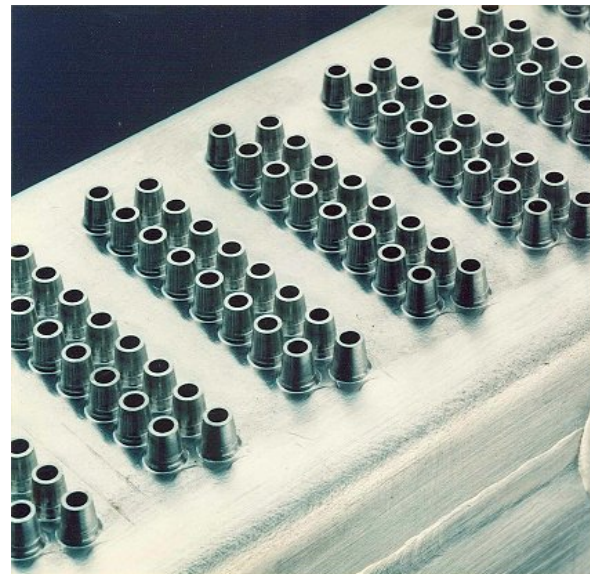

Figure 4b: Typical example.

**Figure 4:** Bushing with pressed tips.

The main disadvantages of designs with pressed tips are the relatively high tooling cost and the time delay if new tooling has to be manufactured. Furthermore, each tip-plate design requires its own tooling. The thickness tolerances that can be achieved for the tip-plate are less precise than for the rolled sheet used in making tip-plates with welded tips. It is, of course, not possible to use different materials for tips and plate.

### Glass quality

Table 1 shows typical compositions of the main glasses used for fibres. Platinum alloys are used for bushings because of their excellent oxidation and corrosion resistance. However, they are susceptible to attack by “platinum poisons” – elements which form low-melting eutectics or brittle compounds with the platinum. A number of these “poisons” can develop if the glass processing conditions are insufficiently oxidising. One of the best known examples is silicon which forms a eutectic with platinum melting at only 830°C. Less well known is the reaction of the rhodium constituent of Pt-Rh alloys with sulphur to form a eutectic which melts at 925°C. Under sufficiently reducing conditions, even the highly stable oxide  $Al_2O_3$  can be reduced at the surface of platinum: the aluminium diffuses into the platinum causing embrittlement. The insufficiently oxidising conditions may be the result of carbon impurities in the raw materials, incorrect adjustment of the oxygen potential in the furnace atmosphere or unintentional galvanic effects in the electrical heating system.

<b>Chemical compositions of glasses for fibres</b>										
<i>Composition in wt% ( typical values )</i>										
<b>Oxide</b>	<b>E-Glass</b>	<b>C-Glass</b>	<b>S-Glass</b>	<b>A-Glass</b>	<b>D-Glass</b>	<b>R-Glass</b>	<b>ECR-Glass</b>	<b>Basalt</b>		
<b>SiO<sub>2</sub></b>	55.0	66.0	65.0	67.5	74.0	60.0	61.0	52.0		
<b>Al<sub>2</sub>O<sub>3</sub></b>	14.0	4.0	25.0	3.5	---	24.0	13.0	17.2		
<b>TiO<sub>2</sub></b>	0.2	---	---	---	---	---	---	1.0		
<b>B<sub>2</sub>O<sub>3</sub></b>	7.0	5.0	---	1.5	22.5	---	---	---		
<b>CaO</b>	22.0	14.0	---	6.5	---	9.0	22.0	8.6		
<b>MgO</b>	1.0	3.0	10.0	4.5	---	6.0	3.0	5.2		
<b>Na<sub>2</sub>O</b>	0.5	38844,0	---	13.5	1.5	0.5	---	5.0		
<b>K<sub>2</sub>O</b>	0.3	0.5	---	3.0	2.0	0.1	0.5	1.0		
<b>Fe<sub>2</sub>O<sub>3</sub></b>	---	---	---	---	---	---	---	5.0		
<b>Softening Point</b>	840°C	750°C	950°C	700°C	720°C	950°C	840°C	---		

**Table 1:** Typical glass compositions.

## Bushing design

Many constraints and parameters must be considered in the design of a bushing. The basic geometrical aspects relate to the type of fibres to be produced and the choice of the melt system (indirect or direct). The thermal household is, however, also of fundamental importance. The aim of the fiberising process is to produce filaments with a uniform diameter. This is only possible if the temperature of the glass as it leaves the bushing via all the tips is uniform to within a few degrees. Marble bushings are subject to the additional constraint that a considerable amount of electrical energy is required to melt the marbles on the upper perforated sheet. The electrical design of a bushing can be considered as a number of resistors connected in parallel, the individual resistors being the walls, sheets and plates.

The **electrical connecting flanges** are of decisive importance in achieving a homogeneous temperature distribution in the bushing. Typical designs of connecting flanges are shown in Figures 5a, 5b and 5c. The electrical energy is introduced by means of water-cooled copper clamps. The clamps also remove thermal energy and can thus be used for cooling specific parts of the bushing .

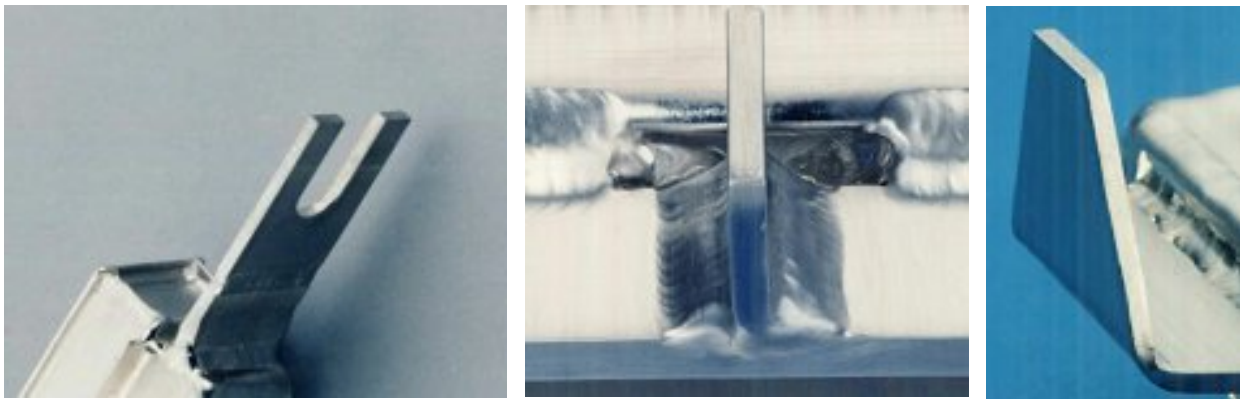

**Figure 5:** Three typical examples of electrical connecting flanges.

The **tip-plate** is the essential feature of the bushing. The larger the tip-plate, the greater the danger that it will start to sag in operation. Sagging has two negative effects on the function of the bushing: the hydrostatic head of glass is no longer uniform over the whole area of the tip-plate, and the tips are no longer parallel to each other. Double bottom-plates are supported additionally by a central support along the longitudinal axis, thus ensuring greater mechanical stability, Figure 6. The stability of single tip-plates can only be increased by numerous reinforcement ribs inside the bushing.

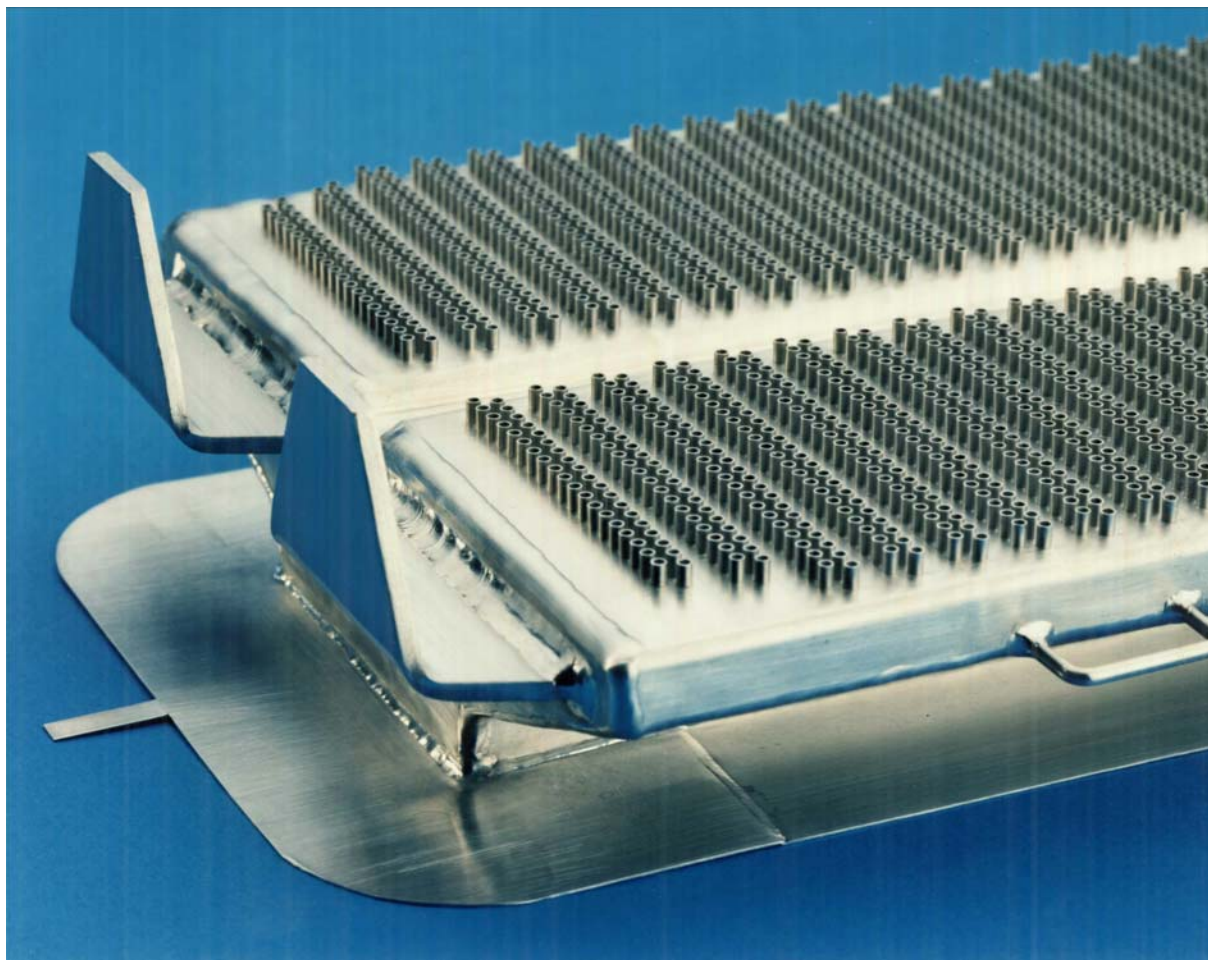

**Figure 6:** Bushing with double bottom plate for increased mechanical stability.

It is normal practice to cool the glass fibres as they leave the bushing by means of **cooling fins**, Figures 7a and 7b. These have the additional function of cooling the lower part of the tips to increase the glass viscosity at the point where the fibre drawing occurs. Important features are both the material and the dimensions of the fins. Typical materials used are copper, which may be plated with nickel or silver, or water-cooled palladium.

To increase the output of bushings, increasingly large **tip-counts** are being used. Bushings with 4000 tips are now in common use, whereas individual fibre manufacturers are already using 6000-tip bushings. However, as there is a practical limit to the physical size of the bottom-plate because of the stability requirement, an increase in the tip-count can only be achieved by an increase in the tips per unit area – a gap of only 0.8 mm between tips can now be achieved with a tip-plate thickness of 1.5 mm.

A further design feature is the **geometry of the tip** which influences both the fibre quality and the performance of the bushing. Modern techniques of metal forming and machining permit a wide variety of geometries. Heraeus has, for example, about 20 geometries in the standard product range.

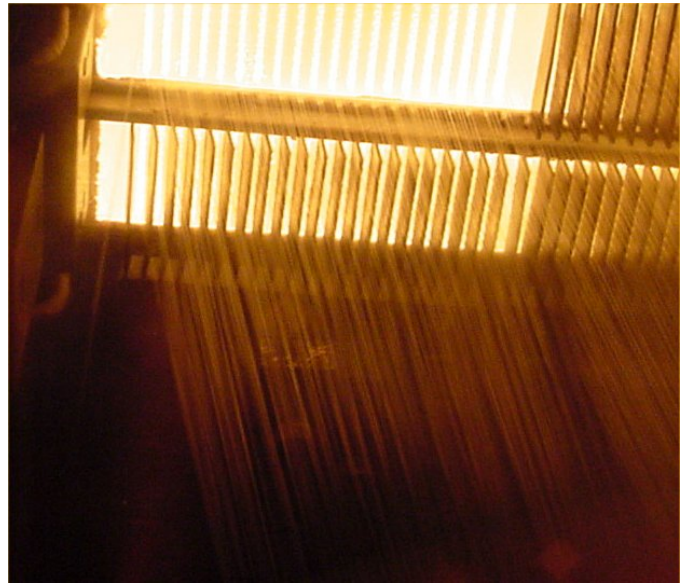

Figure 7a: Small unit of cooling fins. Figure 7b: Cooling fins in fibre drawing process

**Figure 7:** Cooling fins.

### **Manufacture of bushings**

The manufacturing quality is of critical importance for the service life of the bushing. It is essential that the materials used have a high level of purity. Joints between sheets and other parts are only acceptable if the welds are free from all defects. The integrity of all welds must be inspected by a dye-penetrant test. The tolerances of all sheets, tubes and wires must be maintained within very tight limits to ensure the problem-free function of the bushing regarding temperature homogeneity and mechanical stability. The achievement of closely defined tolerances is also important in optimising the weight of precious metal used in the bushing.

Another factor in minimising the weight of bushings is the possibility of combining different Pt-Rh materials to optimise strength in the components where stability is particularly needed. A typical example is the use of an oxide dispersion hardened alloy, e.g. Pt-10%Rh DPH, for the tip-plate to reduce sagging. The DPH materials have considerably higher creep strength than the conventional alloys at high temperatures.[5]

### **Glass forming operation**

Before the bushing is taken into operation, it must be cautiously embedded in a high purity refractory cement. It is absolutely essential that the bushing should be able to expand and contract freely. The thermal expansion of the bushing during heating to the operating temperature is very considerable (typically several millimetres over the length of the bushing). The heating operation – and any subsequent cooling operations for cleaning or repair – must be carried out slowly to minimise thermally

induced stresses which arise due to temperature gradients within the bushing and between the bushing and surrounding refractories.[6] The expansion of the bushing must not be hindered by the electrical contact clamps. Additionally, it is generally recommended to bond a layer of alumina fibre felt to the bushing to prevent direct contact with the cement. Apart from reducing stresses, the felt protects the bushing from corrosion by impurities in the cement and reduces metal losses resulting from the oxidation and evaporation of the platinum and rhodium constituents in the alloy. A further, rather sensitive aspect with regard to the service life of a bushing is the qualification of the operative responsible for the bushing in service. For example, it is extremely important that, when removing glass from between the tips with the commonly used steel wires, the wire is not allowed to touch the tip-plate. This can lead to a contamination of the platinum with impurities which diffuse into the platinum alloy in the affected areas and then cause corrosion damage or even embrittlement of the material.

When cleaning the cooling fins it is essential to ensure that the tip-plate is not cooled excessively. The rapid cooling in this region causes the heating power to increase very rapidly which can result in the joints to the connecting flanges overheating and melting.

The glass processing steps prior to the fiberisation also play a major role in the function of the bushing. Defects in the glass stream which are caused by faults in the melting process cannot be corrected by the bushing. Temperature variations in the glass, for example, cannot be compensated by the bushing. Undissolved solid particles of the glass batch components clog the perforated sheet and can also act as nuclei for crystallisation. In extreme cases, impurities in the glass can destroy a bushing within a few hours.

### **Future developments**

One of the most important developments will be the wide-scale implementation of bushings with tip-counts of more than 4000. This will, in turn, lead to bushing designs with a higher density of tips on the tip-plate and reduced gaps between the tips. The reduced gap size will mandate the welded design of tip-plate, but it is likely that the tips will be specially formed to simulate the shape of pressed tips in order to increase their stability.

It is to be expected that the oxide dispersion hardened Pt-Rh DPH materials will be used increasingly in bushings. For example, in [5] it was demonstrated that the weight of a marble-bushing for C-glass could be reduced by 8.7% and the service life doubled by converting from conventional Pt-10%Rh to Pt-10%Rh DPH.

The increasing use of finite element modelling (FEM) is leading to significant advances in both the mechanical and thermal design of bushings. FEM permits, for example, the redesign of critically stressed components, the optimisation of operating

conditions and the selection of the most appropriate structural materials.[6] An example of the redesign of part of a bushing is shown in Figure 8.

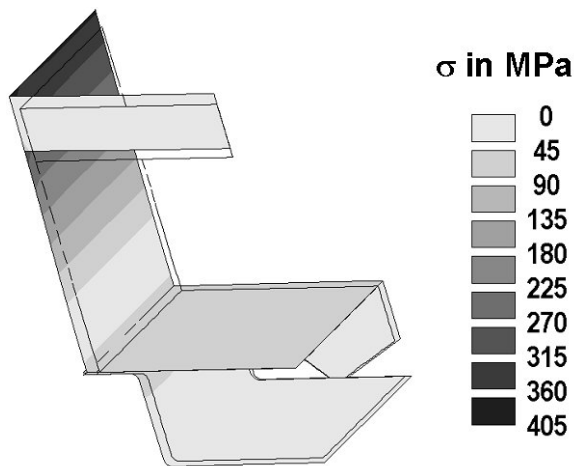

Figure 8a: Stresses caused by the temperature profile shown in Figure 8c in original bushing.

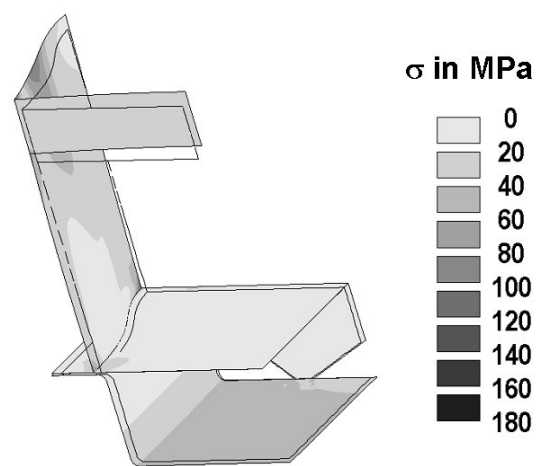

Figure 8b: Stresses caused by the temperature profile shown in Figure 8c in modified bushing.

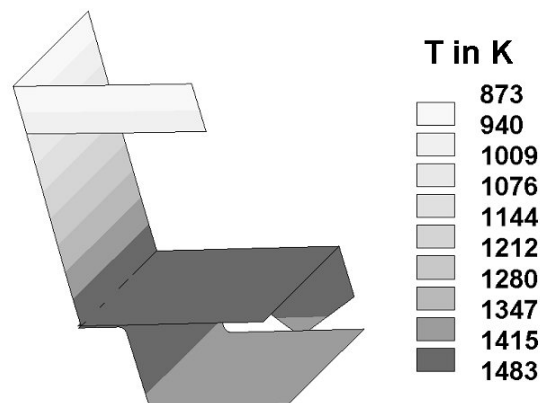

Figure 8c: Temperature profile in a segment of a bushing

**Figure 8:** Example for redesign of bushing segment using FEM to minimise stress concentrations, from [6]

### Acknowledgements

We are grateful to Kari Salonaho, Dr. Roman Teschner and Jürgen Woltz for their useful contributions and constructive discussions regarding the practical applications of glass fibre bushings.

## References

1. <http://www.madehow.com/Volume-2/Fiberglass.html>
2. P. F. Aubourg, C. Crall, J. Hadley, R.D. Kaverman, and D.M. Miller, "Glass Fibers, Ceramics and Glasses," in Engineered Materials Handbook, Vol. 4. ASM International, 1991, pp. 1027-31
3. F. V. Tooley, "Fiberglass, Ceramics and Glasses," in Engineered Materials Handbook, Vol. 4. ASM International, 1991, pp. 402-8
4. [http://www.britglass.org.uk/Files/form3Glass\\_Fibre\\_Manufacture.pdf](http://www.britglass.org.uk/Files/form3Glass_Fibre_Manufacture.pdf)
5. B. Fischer, "New Platinum Materials for High Temperature Applications", Advanced Engineering Materials, 2001, 3(10), pp. 811-820
6. R. Völkl, B. Fischer, R. Teschner, D. F. Lupton, "Finite Element Modelling of Strains and Stresses in Platinum Alloy Bushings for Textile Glass Fibre Production", Glass Science and Technology / Glastechnische Berichte, 2001, 74, pp. 142-151