

Heraeus



Laboratory Equipment

Precious Metals Technology

W. C. Heraeus can look back on more than 150 years experience in the processing of precious metals. Since its foundation the company has devoted itself to platinum and the platinum group metals.

The industrial processing and fabrication of platinum and its alloys form the core of the Business Unit Precious Metals Technology.

Introduction	4
Standard Laboratory Equipment	5
Crucible, high form	6
Crucible, wide form	7
Crucible, cylindrical form	8
Dishes, cylindrical form	9
Lids for crucibles and dishes	10
Special Dishes and Boats	11
Wine dishes, flour ignition dishes, sugar ignition dishes, boats	
Equipment for Microanalysis	12
Crucibles, dishes, boats	
XRF Programme	
Summary of products	13
Crucibles, lids and casting dishes for Autofluxer, Schoeps and Vulcan	14
Crucibles and casting dishes for Katanax	15
Crucibles, lids and casting dishes for OxiFlux	16
Crucibles, lids and casting dishes for Philips PerL-X fusion equipment	17
Crucibles for Claisse Fluxer	18
Crucibles for Leco, Phoenix and Linn fusion equipment	19
Casting dishes for Leco and Claisse Fluxer	19
Crucibles and casting dishes for Herzog fusion equipment	20
Melting moulds for the muffle furnace	21
Other Accessories	
Crucible tongs and plastic formers	22
Tweezers, spatulas, wire triangles and rings	23
Electrodes	
Fischer's electrode	24
Winkler's electrode, Wölbling's electrode, Schöniger's electrode	25
Precious Metal Semifinished Products	
Sheets, foils, strips, gauzes, tubes, wires, wire-wool, discs and perforated discs	26
Thimbles, gauze pieces	27
Crucibles for Crystal Growing	
Pt, Ir, Au, Rh crucibles	28
Special Products	
Custom made parts, metallic fluxes	30
Handling Platinum Equipment	31
Physical and Chemical Properties	36
Material Properties and Possible Applications of Precious Metals and Precious Metal Alloys	38

Everything we achieve at Heraeus today has its origin in an act of technological pioneering: the melting of platinum on an industrial scale. In 1856 the chemist and pharmacist Wilhelm Carl Heraeus was the first man in Germany to accomplish this successfully.

W. C. Heraeus GmbH has again and again produced innovations, transforming unusual technologies into viable industrial processes, thus developing into an important partner for companies in most branches of industry and research.

The Precious Metals Technology of the Engineered Materials Division manufactures, processes and fabricates for technical applications high-value materials requiring complex processing techniques such as platinum, platinum group metals (iridium, rhodium and palladium), gold, silver and their alloys.

The use of precious metals is still absolutely essential because of their good chemical resistance to aggressive media. Precious metals remain stable even at high temperatures.

With dispersion hardening (DPH) Heraeus succeeded in creating a new class of materials in precious metal technology whose resistance to thermal loadings and corrosion resistance is even greater than that of pure platinum and the solid solution hardened platinum alloys.

You can find additional information and technical details in our DPH brochure or on our web site at www.wc-heraeus.com/precious-metals-technology

Based on our long years of experience with precious metals, we can advise you in your choice of materials, the technical design and the handling of your precious metal products. Jointly with you we will check that the optimal version of the laboratory equipment has been selected for your purpose. If you have difficult sample preparation conditions or defective material, we will also be pleased to help you investigate the cause and, together with you, seek alternatives.

Furthermore, the extensive materials expertise of our experienced metallurgists is available to you. The key to the success of our products lies not only in this expertise but also in our quality management certified to DIN EN ISO 9001 and our environmental management certified to DIN ISO 14001.

In this brochure we present, firstly, a range of standardised products. A further focal point of Precious Metals Technology is the development and production of precious metal products exactly to meet customer specifications. We take back your used components and laboratory equipment for processing and reimbursement.

Precious metals are employed in nearly all branches of industry, for instance as:

- A material for crucibles in wet chemical and X-ray fluorescence analysis or ignition
- An inert material for instruments to determine chemical and physical properties
- A material for electrodes in analysis and measurement techniques
- Corrosion resistant materials in the construction of chemical plant
- A material for space technology
- A material for reaction tubes in the polymer industry
- A material for growing single crystals
- Materials for lining melting tanks in the glass industry
- A material for glass fibre bushings and thermocouple thimbles



Especially in chemical analysis, platinum is to be found as the essential material for crucibles and dishes. Chemically pure platinum is used as the standard material for aqueous chemical dissolution and for the ignition or carbonisation of organic substances. As platinum already becomes very soft at application temperatures around 1000° C, platinum/iridium 97/3 is also used. With this small iridium addition, the hardness is increased without negatively influencing the excellent properties of the platinum. However, iridium demonstrates the peculiarity that it oxidises and evaporates at high temperatures, which in the long term results in a loss of weight of the crucibles.

You should not use platinum/iridium alloys if the determination of the weight of the sample before and after the ignition or the dissolution is critical for your technique. Platinum DPH offers a good alternative because it displays higher strength compared with conventional platinum due to

the dispersion hardening and its weight is noticeably more stable than platinum/iridium alloys due to its lower tendency to evaporation. This example shows that the choice of the suitable material is of enormous importance in the successful usage of your laboratory equipment.

We produce the standard laboratory equipment shown on the following pages in a broad range of precious metal materials.

Whether platinum or a platinum alloy is suitable for your particular application depends on the aggressiveness of the substances used and the physical parameters such as temperature, atmosphere, etc.

On page 38 you will find an overview of the most common alloys and some selection criteria for the materials you can best use for your process. We will be delighted to assist you personally in any way we can.

Important Note on Handling:

New items made of precious metals should not touch each other when they are used for the first time in a muffle furnace. Due to the smooth surface the parts weld together. For this reason care must always be taken to keep sufficient distance between them. A new crucible or a new dish should not be covered with a new lid.

To prevent contamination with platinum poisons, which eventually lead to premature failure of the equipment, crucibles and dishes should only be handled with crucible tongs or tweezers with platinum shoes (see our range of accessories on pages 22 – 23).

For further hints on handling platinum see pages 31 – 35.

Crucibles, High Form

Crucibles, high form

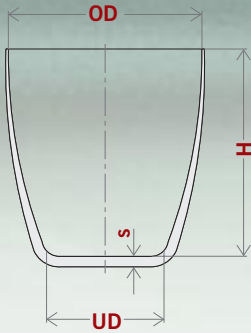

Internal diameter [mm]	Height [mm]	Base thickness [mm]	Norm. capacity [ml]	Weight approx. [g]	Heraeus Standard	
bottom	top					
UD	OD	H	s			
12	19	25	0.20	5	4	Ti 1/1
13	22	27	0.20	8	5	Ti 1/2
14	24	28	0.30	10	8	Ti 1/3
16	26	29	0.30	12	10	Ti 1/4
17	28	33	0.30	15	12	Ti 1/5
18	30	35	0.34	20	18	Ti 1/6
20	34	38	0.34	25	21	Ti 1/7
22	36	40	0.34	30	25	Ti 1/8
25	40	45	0.34	40	30	Ti 1/9
27	45	48	0.34	50	36	Ti 1/10
32	53	56	0.37	75	56	Ti 1/11
35	56	60	0.40	100	70	Ti 1/12

The base thickness given can be increased if necessary to match your requirements.

The weights given refer to platinum.

Deformation and cracks close to the rim limit the operational life of crucibles. The rim can be reinforced with an inlaid welded platinum wire to increase its

mechanical stability. Welding ensures that no cavities are formed in which residues (impurities) can accumulate.

Crucibles, high form, with reinforced rim

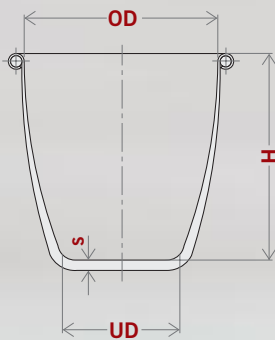

Internal diameter [mm]	Height [mm]	Base thickness [mm]	Norm. capacity [ml]	Weight approx. [g]	Heraeus Standard	
bottom	top					
UD	OD	H	s			
12	19	25	0.20	5	5	Ti 2/1
13	22	27	0.20	8	6	Ti 2/2
14	24	28	0.30	10	9	Ti 2/3
16	26	29	0.30	12	11	Ti 2/4
17	28	33	0.30	15	13	Ti 2/5
18	30	35	0.34	20	19	Ti 2/6
20	34	38	0.34	25	22	Ti 2/7
22	36	40	0.34	30	27	Ti 2/8
25	40	45	0.34	40	32	Ti 2/9
27	45	48	0.34	50	38	Ti 2/10
32	53	56	0.37	75	58	Ti 2/11
35	56	60	0.40	100	72	Ti 2/12

The base thickness given can be increased if necessary to match your requirements.

The weights given refer to platinum.



Crucibles, Wide Form

Crucibles, wide form

Internal diameter [mm]		Height [mm]	Base thickness [mm]	Nom. capacity [ml]	Weight approx. [g]	Heraeus Standard
bottom	top					
UD	OD	H	s			
16	26	20	0.20	5	4	Ti 3/1
18	28	23	0.20	8	5	Ti 3/2
18	29	24	0.30	10	8	Ti 3/3
18	30	25	0.30	12	10	Ti 3/4
19	32	27	0.30	15	12	Ti 3/5
22	34	30	0.34	20	18	Ti 3/6
22	36	32	0.34	25	21	Ti 3/7
22	38	34	0.34	30	25	Ti 3/8
25	45	40	0.34	40	30	Ti 3/9
30	50	42	0.34	50	36	Ti 3/10
36	55	45	0.37	75	51	Ti 3/11
40	62	48	0.40	100	66	Ti 3/12

The base thickness given can be increased if necessary to match your requirements.

The weights given refer to platinum.

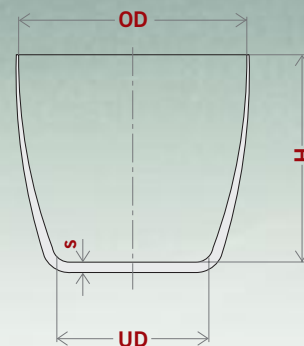

Crucibles, wide form, with reinforced rim

Internal diameter [mm]		Height [mm]	Base thickness [mm]	Nom. capacity [ml]	Weight approx. [g]	Heraeus Standard
bottom	top					
UD	OD	H	s			
16	26	20	0.20	5	5	Ti 4/1
18	28	23	0.20	8	6	Ti 4/2
18	29	24	0.30	10	10	Ti 4/3
18	30	25	0.30	12	11	Ti 4/4
19	32	27	0.30	15	13	Ti 4/5
22	34	30	0.34	20	19	Ti 4/6
22	36	32	0.34	25	22	Ti 4/7
22	38	34	0.34	30	25	Ti 4/8
25	45	40	0.34	40	33	Ti 4/9
30	50	42	0.34	50	38	Ti 4/10
36	55	45	0.37	75	56	Ti 4/11
40	62	48	0.40	100	72	Ti 4/12

The base thickness given can be increased if necessary to match your requirements.

The weights given refer to platinum.

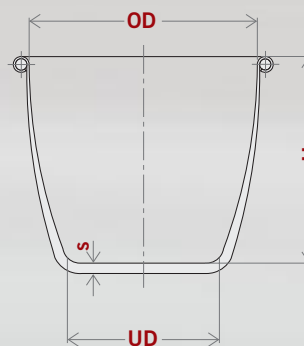

The standard crucibles are also available in cylindrical form.

You can find the dimensions together with the iridium crucibles on page 8.

Cylindrical Crucibles

of platinum and platinum alloys, seamless or welded

Welded,
flat base

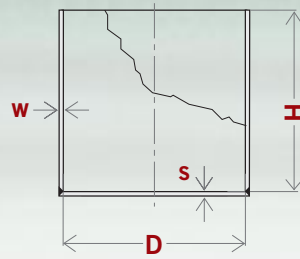

You can obtain cylindrical crucibles in a variety of dimensions to meet your requirements (diameter, height and base thickness).

Tell us what you want to do and you will receive a tailor-made crucible corresponding to your requirement profile in all current alloy variations or in our DPH materials.

Welded,
drawn base

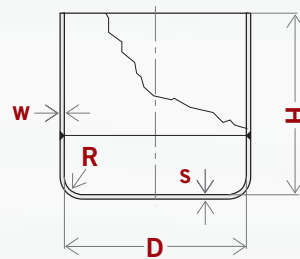

We will be delighted to produce other forms and geometries on request.

Seamless

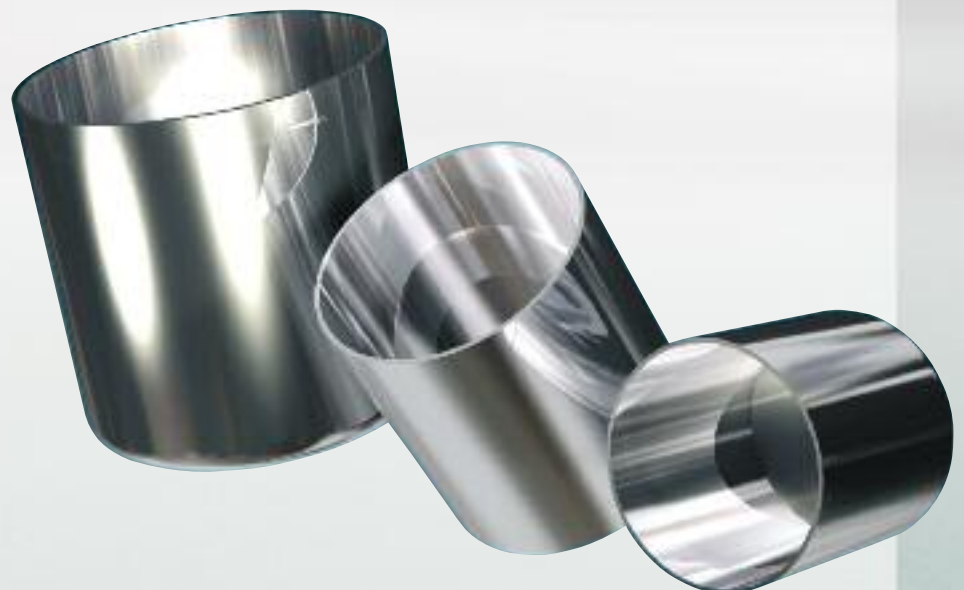
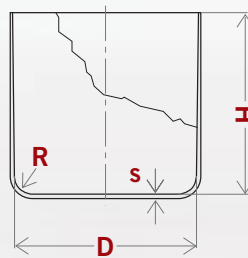

Dishes, Cylindrical Form

Dishes are used mainly for evaporating down solutions or igniting substances.

All dishes can be supplied with or without a pouring lip.

Internal diam. [mm]	Height [mm]	Base thickness [mm]	Nom. capacity [ml]	Weight approx. [g]	Heraeus Standard	
					with pouring lip	without pouring lip
D	H	s				
40	20	0.15	20	9	Scha 1/1	Scha 2/1
50	25	0.16	35	14	Scha 1/2	Scha 2/2
60	30	0.16	50	22	Scha 1/3	Scha 2/3
65	33	0.17	75	28	Scha 1/4	Scha 2/4
70	35	0.18	90	32	Scha 1/5	Scha 2/5
75	38	0.20	130	40	Scha 1/6	Scha 2/6
80	40	0.20	150	48	Scha 1/7	Scha 2/7
90	45	0.22	200	65	Scha 1/8	Scha 2/8
100	50	0.25	250	90	Scha 1/9	Scha 2/9
110	55	0.28	325	125	Scha 1/10	Scha 2/10
120	60	0.28	400	150	Scha 1/11	Scha 2/11
130	65	0.28	500	175	Scha 1/12	Scha 2/12

The base thickness given can be increased if necessary to match your requirements.

The weights given refer to platinum.

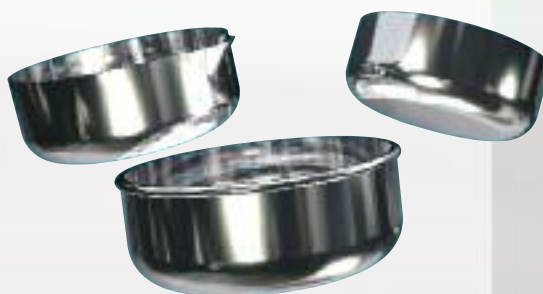

Internal diam. [mm]	Height [mm]	Base thickness [mm]	Nom. capacity [ml]	Weight approx. [g]	Heraeus Standard	
					with pouring lip	without pouring lip
D	H	s				
40	20	0.15	20	12	Scha 3/1	Scha 4/1
50	25	0.16	35	17	Scha 3/2	Scha 4/2
60	30	0.16	50	26	Scha 3/3	Scha 4/3
65	33	0.17	75	33	Scha 3/4	Scha 4/4
70	35	0.18	90	37	Scha 3/5	Scha 4/5
75	38	0.20	130	45	Scha 3/6	Scha 4/6
80	40	0.20	150	55	Scha 3/7	Scha 4/7
90	45	0.22	200	72	Scha 3/8	Scha 4/8
100	50	0.25	250	95	Scha 3/9	Scha 4/9
110	55	0.28	325	131	Scha 3/10	Scha 4/10
120	60	0.28	400	158	Scha 3/11	Scha 4/11
130	65	0.28	500	183	Scha 3/12	Scha 4/12

The base thickness given can be increased if necessary to match your requirements.

The weights given refer to platinum.

Deformation and cracks close to the rim limit the operational life of crucibles. The rim can be reinforced with an inlaid welded platinum wire to increase its

mechanical stability. Welding ensures that no cavities are formed in which residues (impurities) can accumulate.

Dishes, cylindrical form

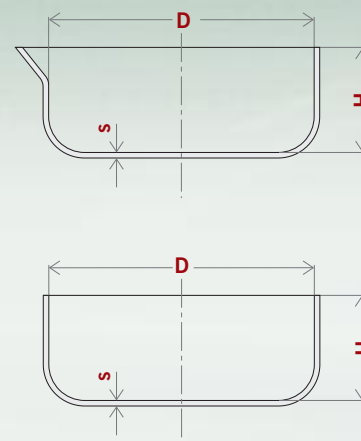

Dishes, cylindrical form with reinforced rim

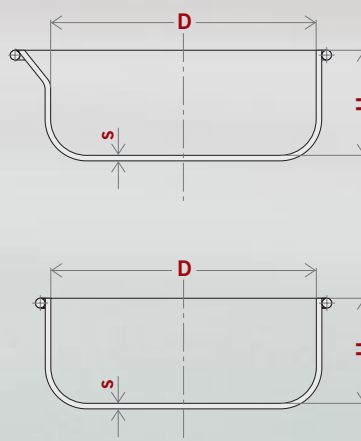

Lids for Crucibles and Dishes

Matching lids for crucibles and dishes

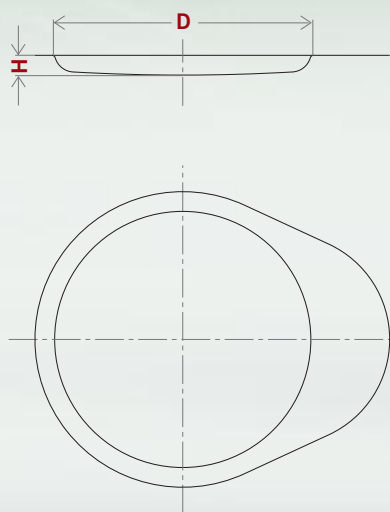

Ø [mm]	Height [mm]	Weight approx. [g]	Heraeus Standard
D	H		
18	2.0	2.0	Tid 1/1
21	3.0	2.0	Tid 1/2
23	3.0	3.0	Tid 1/3
25	3.0	3.0	Tid 1/4
27	3.0	3.0	Tid 1/5
29	3.0	4.0	Tid 1/6
33	3.0	5.0	Tid 1/7
35	3.0	5.0	Tid 1/8
37	4.0	7.0	Tid 3/8
39	3.5	7.0	Tid 1/9
44	4.0	9.0	Tid 1/10
49	3.5	9.0	Schad 1/2
52	4.0	11.0	Tid 1/11
55	3.0	12.0	Tid 1/12
59	4.0	14.0	Schad 1/3
64	4.5	15.0	Schad 1/4
69	5.0	18.0	Schad 1/5
74	5.0	20.0	Schad 1/6
79	6.0	24.0	Schad 1/7
89	7.0	34.0	Schad 1/8
99	8.0	38.0	Schad 1/9
109	9.0	48.0	Schad 1/10
119	10.0	58.0	Schad 1/11
129	12.0	66.0	Schad 1/12

The weights given refer to platinum.

Lids have a flange and are formed with a grip for better handling. They can be supplied for all our standard crucibles and dishes.



Gold alloy dishes with 10 % platinum must be used when determining the ash content of flour (determination of type). They distinguish themselves by their good form stability and weight constancy. Because of the catalytic acceleration of the combustion process they permit rapid

sample processing in the laboratory. Dishes made of platinum/iridium 97/3 or platinum/gold 95/5 are suitable for the determination of residues in wines. The base thickness given can be increased if necessary to match your requirements.

Description	Internal diam. [mm]	Height [mm]	Base thickness [mm]	Nom. capacity [ml]	Weight approx. [g]	Heraeus Standard
	D	H	s			
without pouring lip	85	20	0.12	75	22	Scha 21/1
with pouring lip	85	20	0.12	75	22	Scha 21/2
with reinforced rim, without pouring lip	85	20	0.12	75	27	Scha 21/3
with reinforced rim, with pouring lip	85	20	0.12	75	27	Scha 21/4

The weights given refer to platinum.

Description	Internal diam. [mm]		Height [mm]	Base thickness [mm]	Nom. capacity [ml]	Weight approx. [g]	Heraeus Standard
	bottom	top	H	s			
	UD	OD					
without reinforced rim	36	40	16	0.15	18	7.0	Scha 21/5
with reinforced rim	36	40	16	0.15	18	9.0	Scha 21/6
without reinforced rim	36	45	18	0.15	25	7.2	Scha 22/8
with reinforced rim	36	45	18	0.15	25	9.0	Scha 22/9

The weights given refer to gold/platinum 90/10.

Description	Internal diam. [mm]		Height [mm]	Base thickness [mm]	Nom. capacity [ml]	Weight approx. [g]	Heraeus Standard
	bottom	top	H	s			
	UD	OD					
without reinforced rim	40	45	22	0.20	31	15	Scha 22/6
with reinforced rim	41	47	14	0.20	21	13	Scha 22/7

The weights given refer to gold/platinum 90/10.

Description	Length [mm]	Width [mm]	Sheet thickness [mm]	Blechdicke [mm]	Heraeus Standard
	L1	L2	B	H	s
with grip, form 1	Dimensions on request			0.12	Ge 01/1
with grip, form 2	Dimensions on request			0.12	Ge 01/2
without grip, form 1	Dimensions on request			0.12	Ge 02/1
without grip, form 2	Dimensions on request			0.12	Ge 02/2

L1 = Length without grip

L2 = Length of grip

Wine dishes

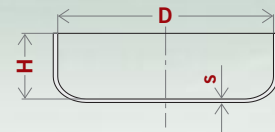

Flour ignition dishes

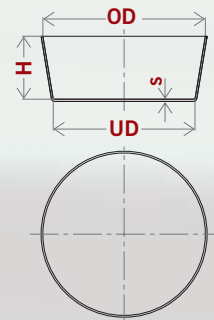

Sugar ignition dishes

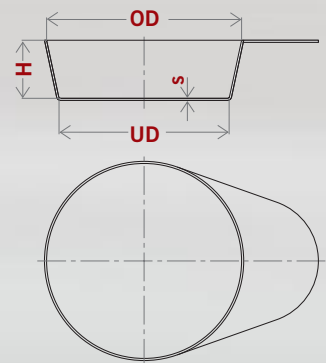

Boats with / without grip

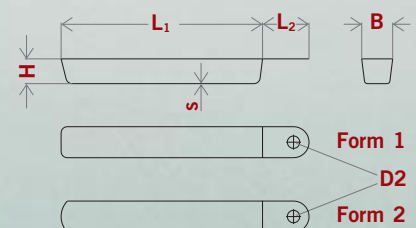

Equipment for Microanalysis



Platinum laboratory equipment for organic microanalysis is used, for example, in the determination of halogens and sulphur.

We produce a large number of different crucibles, dishes and boats in a wide range of dimensions for the various processes in microanalysis such as precipitation, filtration, evaporation, drying and above all for electrolysis.

Chemically inert equipment with good weight constancy is specially important in achieving exact results in microanalysis.

Match-stick size equipment for microanalysis

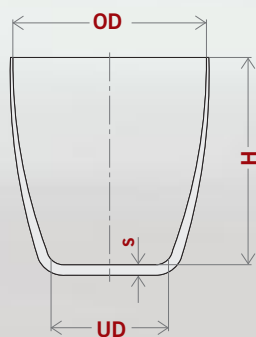

Description	Internal diameter [mm]		Height [mm]	Base thickness [mm]	Weight approx. [g]	Heraeus Standard
	bottom	top				
	UD	OD	H	s		
Crucible	8	12	13	0.18	1.5	Ti 11/1

The weights given refer to platinum.

Description	Internal diameter [mm]	Height [mm]	Base thickness [mm]	Weight approx. [g]	Heraeus Standard
Lid	11	2	0.11	0.6	Ti 11/0
Dish with grip	20	10	0.10	1.5	Scha 22/10

The weights given refer to platinum.

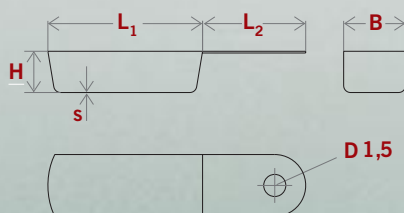
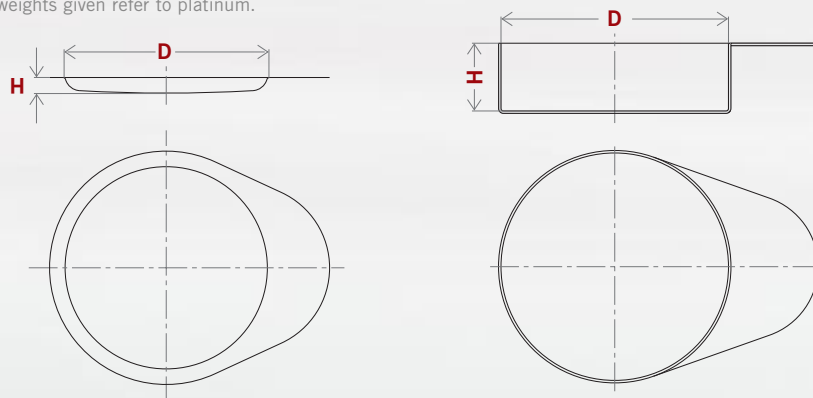

Description	Length [mm]		Width [mm]	Height [mm]	Sheet thckn. [mm]	Weight approx. [g]	Heraeus Standard
	L1	L2					
	L1	L2	B	H	s		
Boats	15	6	4	4	0.10	0.5	Ge 03

L1 = Length without grip L2 = Length of grip

The weights given refer to platinum.

Product Overview:

Crucibles and casting dishes for the preparation of samples for X-ray fluorescence analysis (XRF)

XRF is used for routine quality assurance of the production in many branches of industry. For example, in the iron and steel industry, the manufacture of cement, the animal feed and fertiliser industries, the refractories industry and in all fields of metal processing. Thanks to its high degree of precision, the analysis of samples which have been homogenised by a fusion process is achieving ever increasing importance alongside the direct analysis of powder compacts.

Numerous manufacturers offer fusion equipment for the manual, semi-automatic or fully automatic preparation of samples for XRF analysis.

On the following pages you will find the appropriate crucibles, lids and casting dishes for the most commonly used fusion devices.

The melting moulds presented on page 21 are suitable for the traditional method – sample preparation in the muffle furnace. Here the casting dish is integrated into the crucible by means of a double conical shape. The fused sample does not have to be poured into a separate dish. The melt solidifies in the melting mould and forms a fused bead in the lower conical section.

Alternatively the melt can, of course, be prepared in a standard laboratory crucible and poured into a pre-warmed casting dish.

The inner surface of the casting dishes must be smooth, bright and very flat in order to obtain a microscopically smooth surface on the fused bead. Beam scattering caused by surface effects could lead to false interpretation of the analysis results. Therefore, all our casting dishes undergo a post-treatment and a particularly critical final inspection.



The good stability of platinum, even in the 1100-1200°C temperature range, is further improved by the addition of 5 % gold. The alloy has higher strength and, in particular when melting silicates, a low wettability so that the melt can be removed easily from the crucibles and casting dishes.

Articles made of platinum/gold 95/5 DPH are characterised by a further increase in strength and reduction in grain growth. Their use is to be recommended especially at temperatures above 1150°C as it results in a prolongation of the service life.

The range of designs and sizes of special crucibles and casting dishes is being constantly extended and adapted to new generations of equipment and analysis procedures.

We are pleased to support you in new developments and special wishes.

XRF Programme

Crucibles in platinum/gold 95/5 for Autofluxer, Schoeps and Vulcan

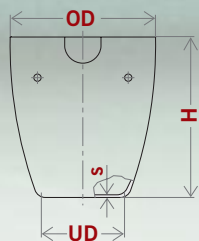

3 or 4 pins,
with or without supp. ring

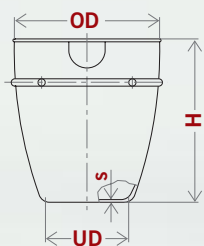

Fusion device	Intern. diameter [mm]		Height [mm]	Base thickness [mm]	Weight approx. [g]	Heraeus drawing No.
	bottom	top				
	UD	OD	H	s		
3 pins	20	34	38	0.34	25	80018374
3 pins	20	34	38	0.68	45	80018374
3 pins on supp. ring	20	34	38	0.34	32	80079008
3 pins on supp. ring	20	34	38	0.50	43	87043878
3 pins on supp. ring	20	34	38	0.68	42	87003992
3 pins on supp. ring, reinforced rim	20	34	38	0.50	44	80049875
4 pins on supp. ring, reinforced rim, two lips	20	34	38	0.50	42	80051293

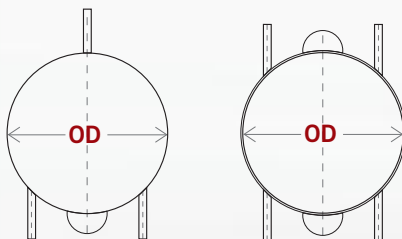

Crucibles in platinum/gold 95/5 for Schoeps

3 x at the circumference (3 x 120°)

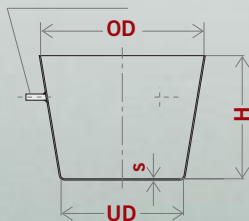

Fusion device	Intern. diameter [mm]		Height [mm]	Base thickness [mm]	Weight approx. [g]	Heraeus drawing No.
	bottom	top				
	UD	OD	H	s		
USG, 3 pins	30	40	30	0.31	20	80003913
USG, 3 pins	30	40	30	0.45	33	80003912
USG, 3 pins	30	43	40	0.30	25	80025664

All casting dishes are also available with a 1.0 mm base thickness.

Lids in platinum/gold 95/5 for Autofluxer, Schoeps and Vulcan

Fusion device	Intern. diameter [mm]	Height [mm]	Weight approx. [g]	Heraeus drawing No.
	D	H		
2 pins	45	–	14.0	80019941
USG	39	3.5	8.5	80003914
USG	42	2.5	8.0	80020167

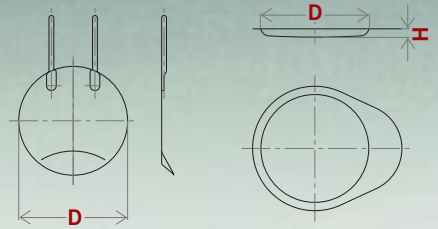

XRF Programme

Casting dishes in platinum/gold 95/5 for Autofluxer, Schoeps and Vulcan

Edge length [mm]	Intern. diameter [mm]		Height [mm]	Base thickness [mm]	Weight approx. [g]	Heraeus drawing No.
	bottom	top				
□B	UD	OD	H	s		
41	29	31.0	3	0.80	27	80001558
41	29	31.6	4	0.80	28	87043235
41	32	34.0	3	0.80	31	80008877
51	34	36.0	3	0.80	45	80008175
51	39	41.0	3	0.80	45	80008176

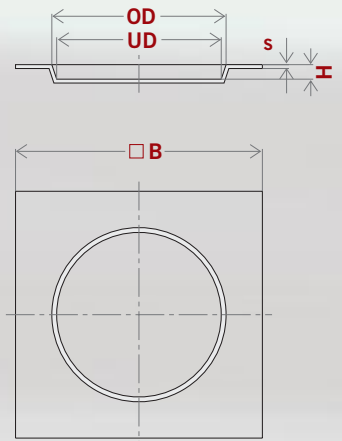

Crucibles and casting dishes in platinum/gold 95/5 for Katanax

Fusion device	Intern. diameter [mm]		Height [mm]	Base thickness [mm]	Weight approx. [g]	Heraeus drawing No.
	bottom	top				
	UD	OD	H	s		
XRF crucible	28	40.5	32	0.34	28	81016795
XRF casting dish	38	40.0	6	0.80	34	81012204

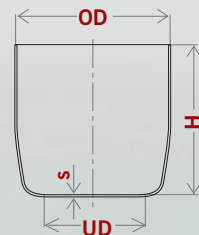
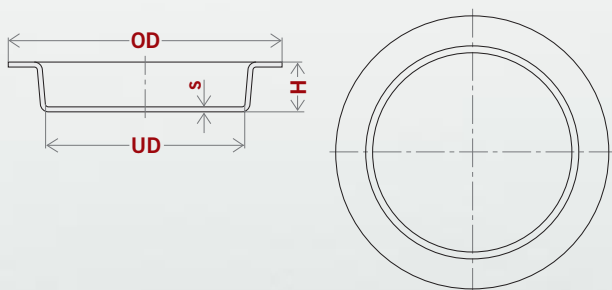

XRF Programme

Crucibles in platinum/gold 95/5 for the OxiFlux fusion system

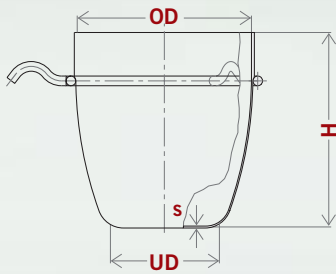
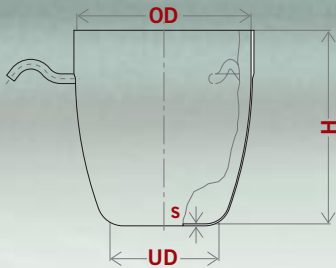

Fusion device	Intern. diameter [mm]		Height [mm]	Base thickness [mm]	Weight approx. [g]	Heraeus drawing No.
	bottom	top				
	UD	OD	H	s		
3 pins	22	36	40	0.34	28	80063493
3 pins on supp. ring	22	36	40	0.34	38	80063494



Lid in platinum/gold 95/5 for the OxiFlux fusion system

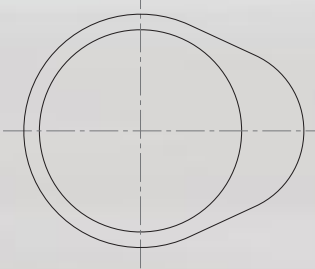

Description	Intern. diameter [mm]	Height [mm]	Weight approx. [g]	Heraeus drawing No.
	D	H		
To match crucible Heraeus drawing No. 80063493	35	3	5.5	Tid 1/8
To match crucible Heraeus drawing No. 80063494	35	3	5.5	Tid 1/8

Casting dishes in platinum/gold 95/5 for the OxiFlux fusion system

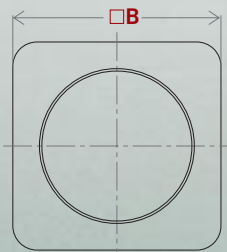
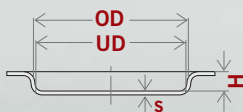

Edge length [mm]	Intern. diameter [mm]		Height [mm]	Base thickness [mm]	Weight approx. [g]	Heraeus drawing No.
	bottom	top				
□B	UD	OD	H	s		
43	31	32	4.5	0.80	30	80071972
45	33	35	4.5	0.80	33	80076170
51	39	40	4.5	0.80	45	80063492

Crucibles in platinum/gold 95/5 for Philips Perl-X fusion equipment

Description	Intern. diameter [mm]		Height [mm]	Base thickness [mm]	Weight approx. [g]	Heraeus drawing No.	
	bottom	top					
	UD	OD	H	s			
cylindrical		41	40	0.80	85	80046699	NBX U3
	32	40	40	0.60	67	80073969	
	41/32	50	40	1.10	98	2370102	NBXU3N
	41/32	50	40	0.80	78	2370103	NBXU3NL

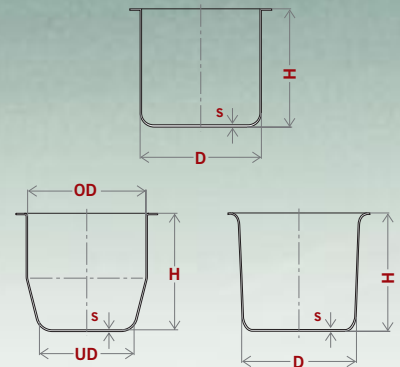

Lids in platinum/gold 95/5 for Philips Perl-X fusion equipment

Description	Intern. diameter [mm]	Height [mm]	Base thickness [mm]	Weight approx. [g]	Heraeus drawing No.
	D	H	s		
Standard, Perl-X-2	55	60	0.50	27	80068494

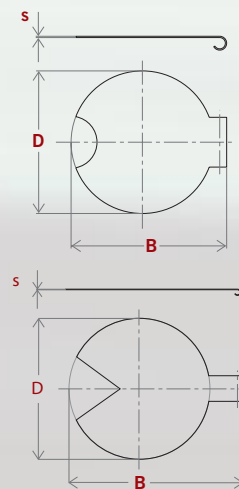

Casting dishes in platinum/gold 95/5 for Philips Perl-X fusion equipment

Ext. diameter [mm]	Intern. diam. [mm]		Int. height [mm]	Base thickness [mm]	Weight approx. [g]	Heraeus drawing No.	
	bottom	top					
AD	UD	OD	H	s			
60	29	32.4	3.6	1	60	4570125	NBX PXR60
65	30	32.4	3.6	0.7	54	4570103	NBX PX
55	30.5	32	2.5	1	50	4570107	NBX P3R
65	30.5	32	3.5	1	60	80050321	NBX PXR
65	30.5	32	4	1	60	80064863	
65	33.5	35.5	3.4	0.7	48	4570105	NBX P16
55	34.5	37	3.5	1	46	80046700	
65	38.5	40	4.5	1	66	80077303	
65	39	41	3.4	1.5	120	4570102	NBX P14RR
60	39.4	40.5	3.5	1	65	4570123	NBX P15R60
65	39.5	40.5	3.5	0.8	55	80077497	NBX P14
65	39.5	40.5	3.5	0.7	52	4570126	NBX P15
65	39.5	40.5	3.5	1	60	80077497	NBX P15R
65	39.5	40.5	3.5	1.5	121	4570130	NBX P15RR
65	39.5	41.5	3.5	1	70	80071030	
65	39.5	41.5	3.5	1.0	70	80071030	

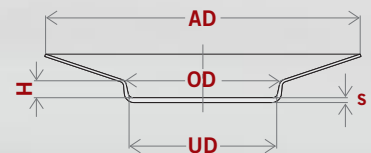

All casting dishes are also available with a 1.0 mm base thickness.

XRF Programme

Crucibles in platinum/gold 95/5 for Claisse Fluxer

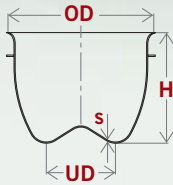
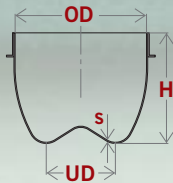

	Internal diameter [mm]		Height [mm]	Base thickness [mm]	Weight approx. [g]	Heraeus drawing No.
	bottom	top				
	UD	OD	H	s		
	20	38	32	0.34	31	80056631
Rim rolled outwards	20	38	32	0.34	31	81004262



Casting dishes in platinum/gold 95/5 for Claisse Fluxer

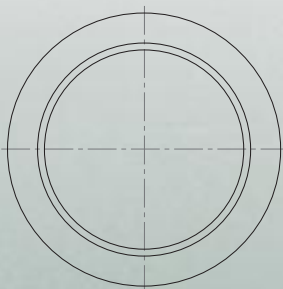
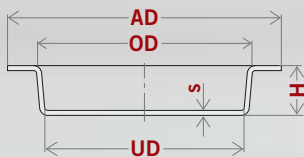

External diameter with rim [mm]	Intern. diameter [mm]		Height [mm]	Base thickness [mm]	Weight approx. [g]	Heraeus drawing No.
	bottom	top				
AD	UD	OD	H	s		
40	30	31	6	0.80	28	80056630/4a
42	32	33	6	0.80	29	80056630/4a
45	35	36	6	0.80	30	80056630/4a
50	40	41	6	0.80	34	80056630/4a

	Intern. diameter [mm]		Height [mm]	Base thickness [mm]	Weight approx. [g]	Heraeus drawing No.
	bottom	top				
	UD	OD	H	s		
	20	37	35	0.46	36	80057336

Crucibles in platinum/gold 95/5 for Leco and Phoenix fusion equipment

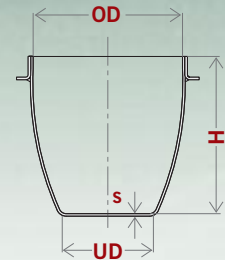

XRF Programme

External diameter with rim [mm]	Intern. diameter [mm]		External height [mm]	Base thickness [mm]	Weight approx. [g]	Heraeus drawing No.
	bottom					
AD	UD	H	s			
44	32	8.0	0.80	28	80057337	
44	35	8.0	0.80	30	80057337	
44	38	8.0	0.80	30	80057337	
44	40	7.2	0.80	40	87047741	

Casting dishes in platinum/gold 95/5 for Leco fusion equipment

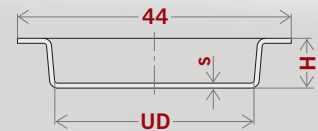

	Intern. diameter [mm]		Height [mm]	Base thickness [mm]	Weight approx. [g]	Heraeus drawing No.
	bottom	top				
	UD	OD	H	s		
	20	35	48	0.43	35	80018112

You can find the appropriate casting dishes with the standard equipment on page 15.



Crucibles in platinum/gold 95/5 for Linn fusion equipment



XRF Programme

Crucibles in platinum/gold 95/5 for Herzog fusion equipment

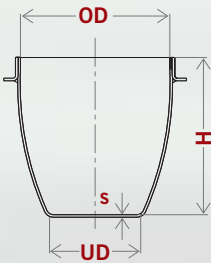
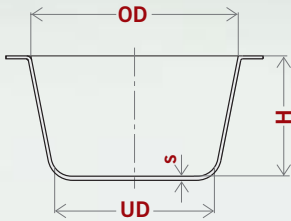
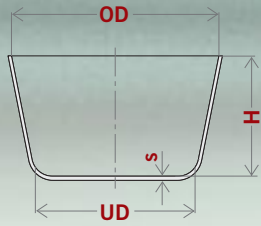

Casting dishes in platinum/gold 95/5 for Herzog fusion equipment

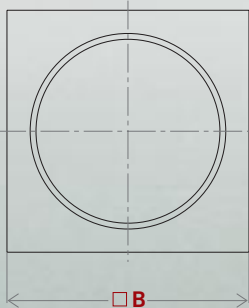
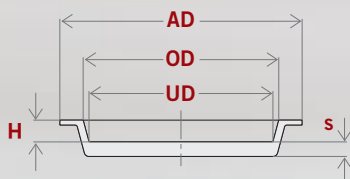

Description	Intern. diameter [mm]		Height [mm]	Base thickness [mm]	Weight approx. [g]	Heraeus drawing No.
	bottom	top				
	UD	OD	H	s		
without rim	38.5	50.0	30.0	0.80	76	80047806
without rim	38.5	50.0	30.0	1.00	90	80047806
without rim	38.5	50.0	30.0	1.15	115	80047806
with rim	38.5	50.0	30.0	1.00	113	80303231
with domed base, with rim	38.5	50.0	30.0	1.00	115	80077307
with crucible support	22.0	36.0	38.5	0.60	52	80308811



External diameter with rim [mm]	Intern. diameter [mm]		Height [mm]	Base thickness [mm]	Weight approx. [g]	Heraeus drawing No.
	bottom	top				
AD	UD	OD	H	s		
44	29	31	3.5	2.5	65	80308810

Edge length [mm]	Intern. diameter [mm]		Height [mm]	Base thickness [mm]	Weight approx. [g]	Heraeus drawing No.
	bottom	top				
□B	UD	OD	H	s		
50	38	40	4.5	3.0	113	80058232

See our standard programme on page 9 for further casting dishes and dimensions or contact us directly.

Melting moulds in platinum/gold 95/5 for the muffle furnace

Double cone form [mm]	Int. diameter [mm]		Height [mm]	Base thickness [mm]	Weight approx. [g]	Heraeus drawing No.
	bottom	top				
D	UD	OD	H	s		
30.3	25.0	34.0	39.3	0.80	47	80073900
34.0	29.0	38.0	39.3	0.80	55	80009988
34.0	32.0	44.0	30.0	0.80	57	80018228
41.0	36.0	43.0	27.3	0.80	63	80023469
41.0	36.0	43.5	33.0	0.80	60	80061266
41.0	36.0	45.0	43.3	0.80	76	80008878
43.0	38.0	47.0	39.3	0.80	75	80072416
42.0	40.0	52.0	30.0	1.50	96	80049081

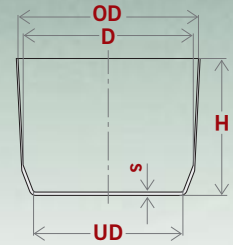

Other Accessories

Heraeus produces a very wide range of handling equipment in precious metals and alloys. In order to prevent contamination

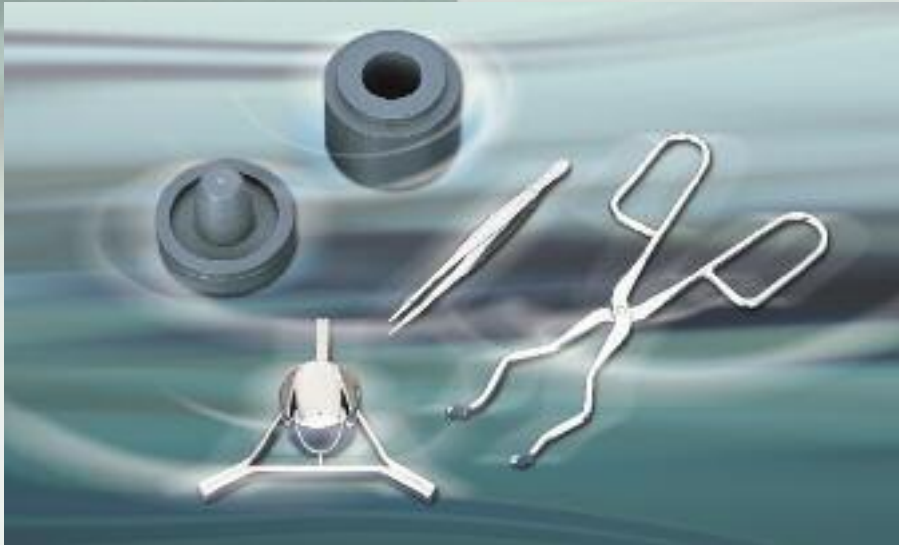

of the precious metal equipment when placing it in the furnace or when removing it, conventional crucible tongs are fitted with platinum shoes or with solid platinum tips. If required, the shoes can be extended right up to the pivot of the crucible tongs.

Tweezers can also be fitted with tips of platinum or platinum/iridium 90/10.

To avoid contamination of the crucible we offer crucible triangles of platinum wire or in Hebebrand's design with buttons of platinum/iridium 95/5 for use when melting materials in a crucible over a Bunsen burner.

Crucible tongs in stainless steel

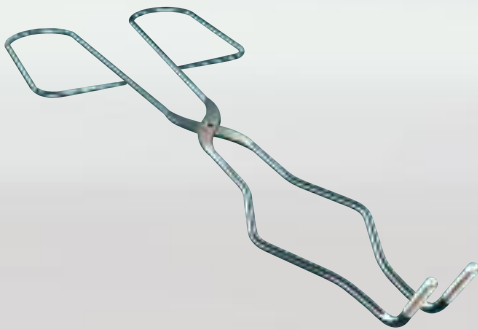

Description	Total length of the tongs [mm]	Weight per pair of shoes approx. [g]	Heraeus Standard
with pt shoes	230	2	Ge 20
with pt shoes	300	3	Ge 20
with pt shoes	400	7	Ge 20
with pt shoes	500	8	Ge 20
with pt shoes	600	9	Ge 20
with solid platelets PtIr 90/10	230	4	Ge 21
with solid platelets PtIr 90/10	300	4	Ge 21
with solid platelets PtIr 90/10	400	4	Ge 21
with solid platelets PtIr 90/10	500	4	Ge 21
with solid platelets PtIr 90/10	600	12	Ge 21
with solid tips	230	20	Ge 22
with solid tips	300	20	Ge 22
with solid tips	400	20	Ge 22
with solid tips	500	20	Ge 22
with solid tips	600	20	Ge 22

Crucible tongs with extended platinum shoes available on request.

Plastic formers



Description
for crucibles and dishes without lid storage
for crucibles and dishes with lid storage
for crucibles and dishes with reinforced rim
for crucibles and dishes with reinforced rim with lid storage
for dishes with a capacity of 250 ml and more

Items of precious metal laboratory equipment are sensitive to mechanical deformation due to their use at high temperatures and the resulting loss of their original hardness. The walls of the crucibles and dishes can become wrinkled after they have been used

several times, thus making cleaning more difficult. The shape can be restored by carefully using a wooden stick to form the platinum at room temperature. To simplify the process we produce plastic formers which match the crucible and dish sizes you use.

Tweezers in stainless steel

Description	Total length of the tweezers [mm]	Weight per pair of shoes approx. [g]	Heraeus drawing No.
with riveted Pt platelets	approx. 130	3–4	87001412

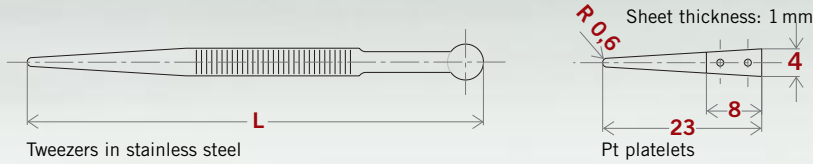

Description	Heraeus Standard
Platinum spatulas are available in various shapes and lengths. Please give us the relevant dimensions for your requirements.	GE 40 GE 50 GE 51 GE 52

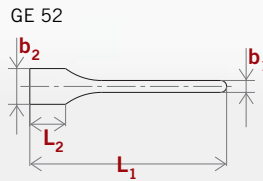
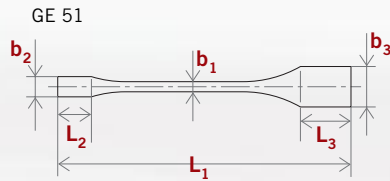
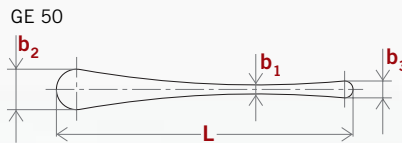
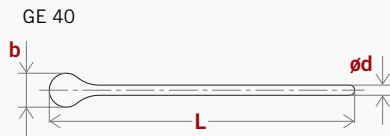

Description	Heraeus Standard
Platinum with fused ends	Ge 10
Chromium-nickel steel triangle according to Hebebrand with Pt/Ir 95/5 buttons, approx. 1 g each	Ge 11

When ordering, please state crucible size and the Heraeus standard.

Wire triangles for various crucible sizes

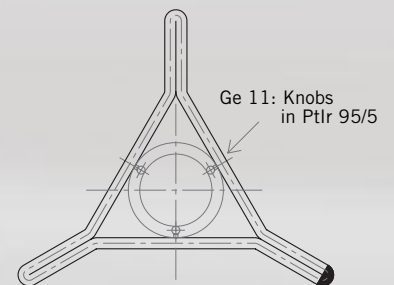

Platinum/iridium 90/10 eyelets

	Wire diameter [mm]	Int. diameter eyelet [mm]	Length [mm]	Weight approx. [g]	Heraeus drawing No.
D Di L					
Eyelets (ends brazed) for microbiology and medical applications					
	0.6	1.24	60	0.40	Ge 30
	0.5	1.00	60	0.27	Ge 30
	0.5	2.00	60	0.28	Ge 30
	0.5	3.00	60	0.29	Ge 30
	0.5	5.00	60	0.30	Ge 30
	0.2	2.00	30	0.03	Ge 30
	0.7	2.00	70	0.65	Ge 30
	0.6	2.60	60	0.60	Ge 30

Different diameters and lengths are available on request.

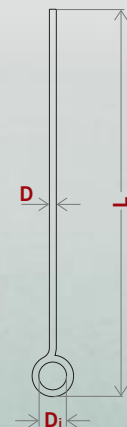

Electrodes



Platinum and platinum alloys distinguish themselves as electrode materials because of their high electrical conductivity and resistance to chemical attack.

Platinum/iridium 90/10 is used as the electrode material to ensure mechanical stability.

The following tables show different electrode designs of which only the most common are listed. To increase the surface area, electrodes can be sand-blasted if required (Fischer electrodes are always sand-blasted). We will be pleased to produce special electrodes on request.

Electrodes of platinum/iridium 90/10

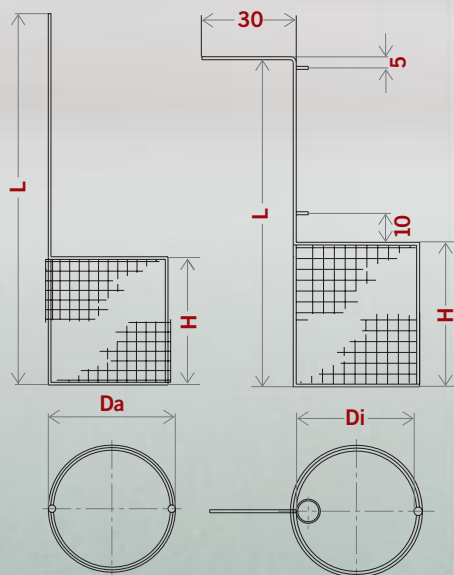

Description	Total height [mm]	Electrode height [mm]	Diameter int./ext. [mm]	Diameter wire [mm]	Weight approx. [g]	Heraeus Standard
	L	H	Di/Da			
Fischer electrode	To increase the surface area of the wire, the electrode is sand-blasted. Suitable for fast tests with high current densities in stirred or still electrolytes.					
inner electrode	200	40	32 (Da)	0.12	14.5	EI 03/1
inner electrode	200	40	32 (Da)	0.25	20.0	EI 03/2
outer electrode	125	50	38 (Di)	0.12	16.5	EI 04/1
outer electrode	125	50	38 (Di)	0.25	23.0	EI 04/2

Electrodes of platinum/iridium 90/10

Description	Total height [mm]	Electrode height [mm]	Diameter int./ext. [mm]	Diameter wire [mm]	Weight approx. [g]	Heraeus Standard
L		H	Di/Da			
Winkler electrode	This design consists of a slit gauze cylinder in which a wire spiral is concentrically positioned.					
Gauze cylinder	100	50	35	0.12	16.0	EI 01/1
Gauze cylinder	100	50	35	0.25	22.5	EI 01/2
Spiral	80	70	10	1.10	7.5	EI 02

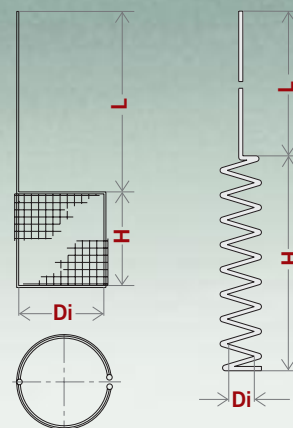

Description	Total height [mm]	Electrode height [mm]	Diameter int./ext. [mm]	Diameter wire [mm]	Weight approx. [g]	Heraeus Standard
L		H	Di/Da			
Wöbling electrode	In this electrode the gauze is fixed stably to the central rod at the top and bottom via a solid cross.					
	100	40	20	0.12	11.5	EI 05/1
	100	40	20	0.25	14.5	EI 05/2
	100	40	30	0.12	20.0	EI 05/1
	100	40	30	0.25	26.0	EI 05/2
	80	50	45	0.12	35.0	EI 05/1
	80	50	45	0.25	45.0	EI 05/2

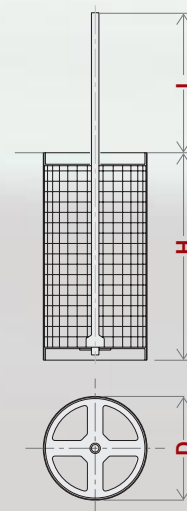

Description	Connection length [mm]	Width [mm]	Electrode height [mm]	Wire diameter [mm]	Weight approx. [g]	Heraeus Standard
L		B	H			
Schöniger electrode	This design consists of a platinum wire mesh bent into a U-shape. It is used mainly for the rapid determination of halogens and sulphur.					
Gauze cylinder	35	10	10	0.76	3.0	EI 06

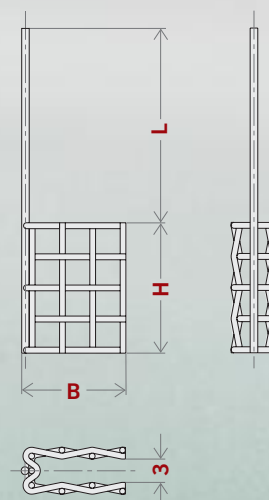

Electrodes / meshes of chemically pure platinum

Precious Metal Semifinished Products

Sheets, foils, strips, gauzes, tubes, thimbles, wires, wire-wool, discs and perforated discs

Jointly we can find the optimum solution to meet your requirements

Semifinished form	Diameter and/or thickness rang
Rods/wires	0.001 – 60 mm
Sheets/foils	0.01 mm – 20 mm
Discs/perforated discs	
Strips, endless	0.01 mm – 1 mm
Tubes, capillaries	0.1 mm – 60 mm
Thermocouple thimbles	see on right page
Bent tubes, seamless	
Granules	
Powder	
Wire-wool	

Iridium	
Rods/wires, profile rolled or swaged	from 0.13 mm (edge length)
Sheet	0.15 mm – 3 mm
Tubes, welded	3 mm (internal diameter) – 30 mm

Rhenium	
Wires	from 0.1 mm
Strips	from 0.03 mm

Heraeus supplies precious metal semi-finished products in a great variety of alloy compositions, dimensions and shapes. Let us know your application criteria and we will be pleased to advise you in choosing the appropriate material.

Platinum wires with a diameter less than 0.01 mm are manufactured by the Wollaston process (i.e. drawn in a silver sleeve). The protective sleeve is etched off immediately prior to use by the customer. We produce the diameters and lengths individually to meet your requirements.

You can have sheets and foils cut to the size you require. Also possible on request are stamped, turned or eroded discs and perforated discs in a great variety of dimensions.

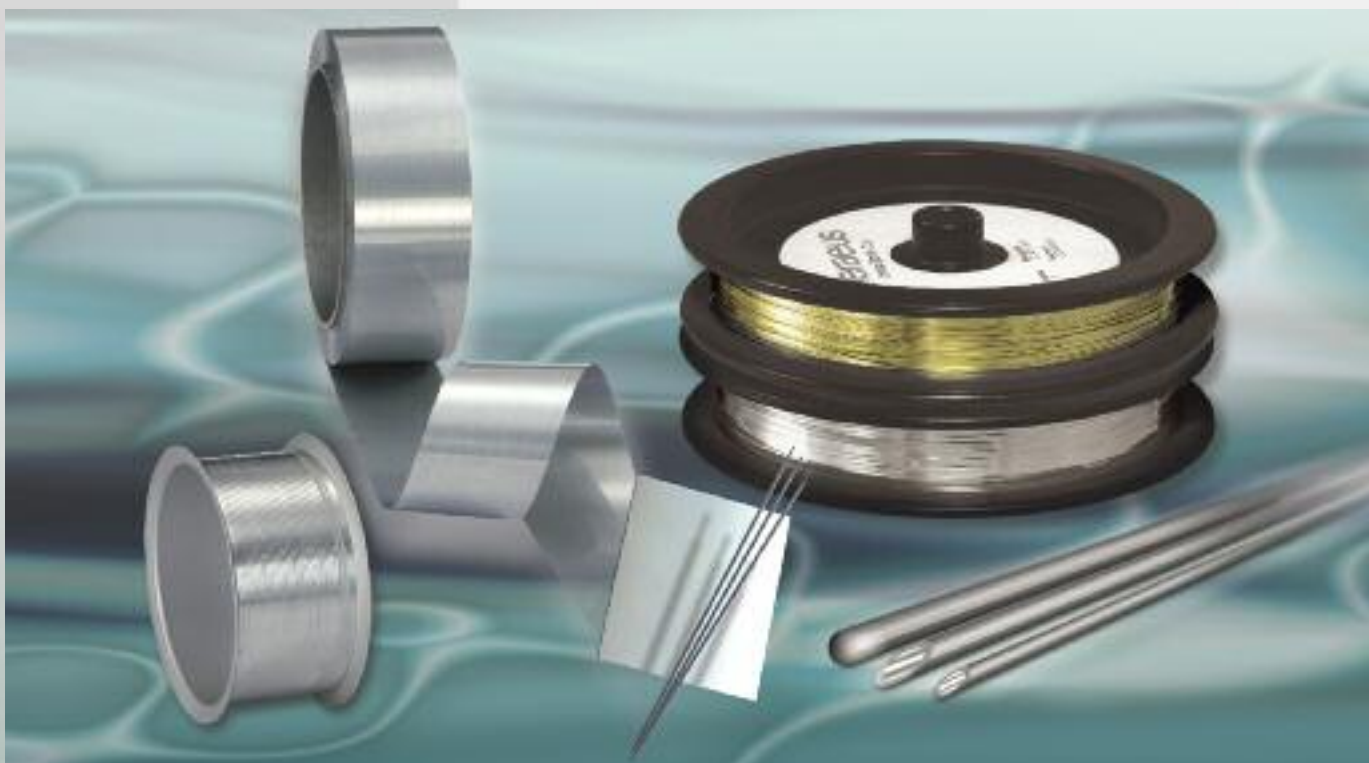

Precious Metal Semifinished Products

Type A



Flat closed

Type B



Flat closed
with flange

Type C



Flat closed
with widened opening

Type D



Half-round closed

Type E



Half-round closed
with flange

Type F



Half-round closed
with widened opening

Thermocouple thimbles

Gauzes for the manufacture of electrodes, filters, catalysts, etc. are available according to the following table even in very small quantities.

Alloy	Wire diameter [mm]	Number of meshes per cm ²	Width of meshes [mm]	Weight per 100 cm ² [g]	Heraeus article No.
Pt	0.760	16	1.700	86.0	87009077
Pt	0.250	100	0.750	22.0	87018193
Pt	0.120	250	0.500	8.0	87011641
Pt	0.060	1024	0.250	4.3	87005955
Pt	0.076	1024	0.200	6.5	87026755
Pt	0.040	3600	0.120	3.6	87022581
Pt	0.120	420	0.370	10.3	81024849
PtRh 90/10	0.060	1024	0.250	4.0	87008190
PtRh 90/10	0.076	1024	0.200	6.0	87007801
PtIr 90/10	0.250	100	0.750	22.0	87013051
PtIr 90/10	0.120	250	0.500	8.0	87021424
Ag	0.350	64	0.900	18.0	87007574
Ag	0.060	1024	0.250	2.0	87023753
Ag	0.120	1024	0.250	7.9	87007615
Au	0.250	100	0.750	19.7	81002110
Au	0.060	1024	0.250	3.7	87016916
AuPt10	0.060	1024	0.250	3.7	87021471

Alloy	Wire diameter [mm]	Weight per 100 cm ² [g]
PtRh 90/10	0.060	4
PtRh 90/10	0.076	6

Gauze pieces (plain weave)

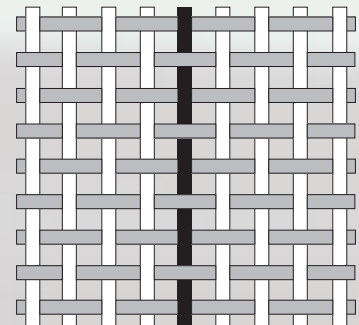

Gauze pieces (warp knitted)



Crucibles for Single Crystal Growing

Only non-alloyed, very pure materials such as platinum, iridium, gold and rhenium can be used for growing single crystals from oxide melts. The crucible shape is generally cylindrical. The melting temperature, the atmosphere and the constituents of the melt determine the choice of material.

For this reason iridium crucibles are used at temperatures up to approx. 2300°C for growing crystals of high melting oxides (e.g. sapphire, spinell) for laser technology and the optical industry.

The use of precious metals is limited to the Czochralski and Bridgman-Stockbarger processes and the crystallisation from hydrothermal solutions. While gold and platinum are suitable for oxidising atmospheres, iridium should, if possible, only be used under inert conditions because the iridium oxides evaporate and can lead to considerable loss in weight.

Under reducing conditions harmful constituents of the melt can result in damage to the iridium crucible.

Heraeus' experience of many years with this material, which is particularly difficult to process, enables us to offer our customers a consistently homogeneous material quality in a wide variety of crucible diameters and heights.

Crucibles are manufactured in seamless and in welded designs.

Our Platinum DPH material has proved itself particularly for crystal growing in oxidising atmospheres due to its higher strength and temperature resistance.

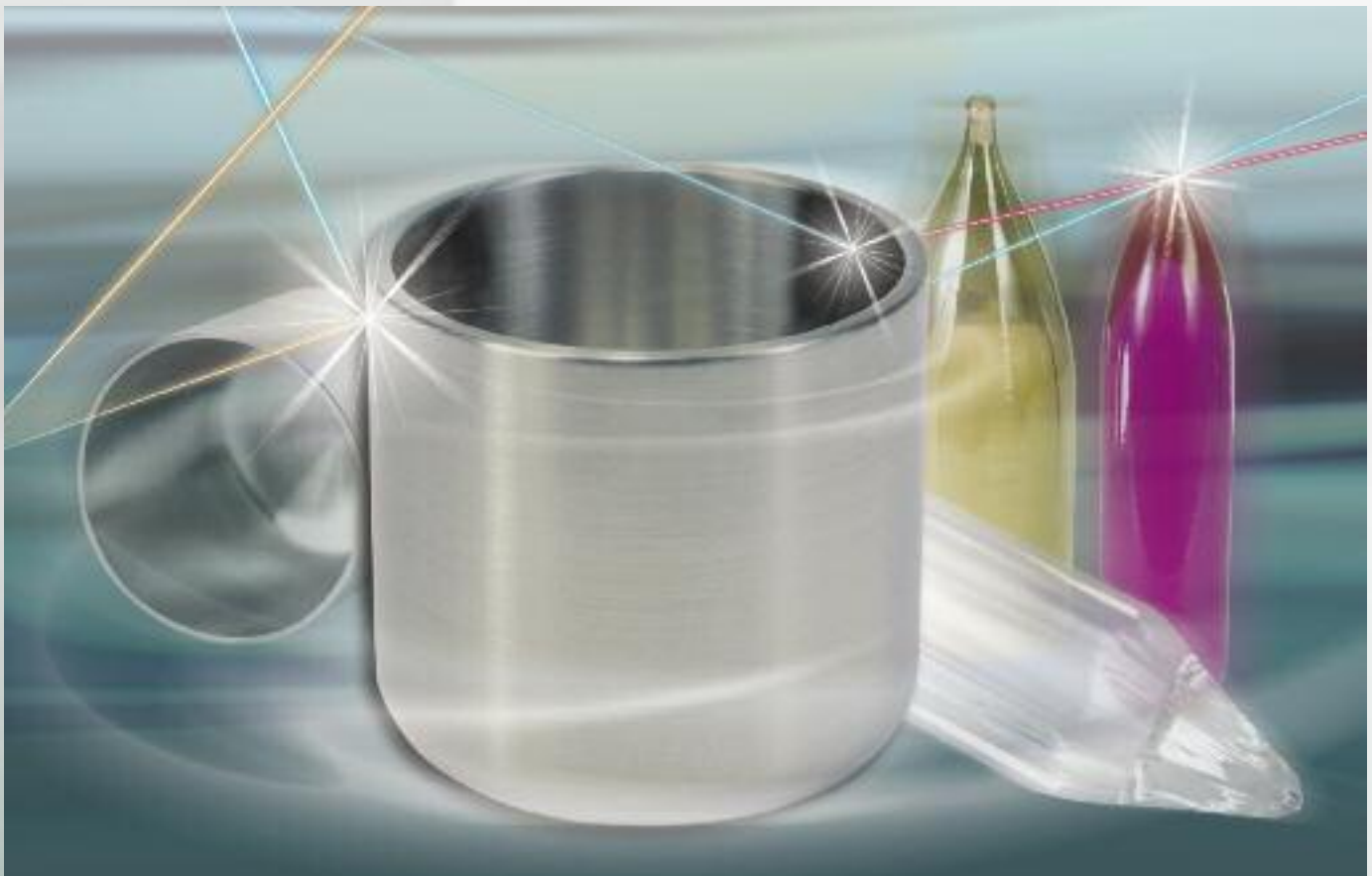

Crucibles for Single Crystal Growing

You can obtain the cylindrical crucibles in a variety of dimensions (diameter, height and base thickness).

Tell us your intended application and you will receive a tailor-made crucible corresponding to your requirements, in all common alloy variations or in our DPH materials.

We will be delighted to produce other forms and geometries on request.

Besides cylindrical crucibles, we also offer conical crucibles with straight walls in iridium.

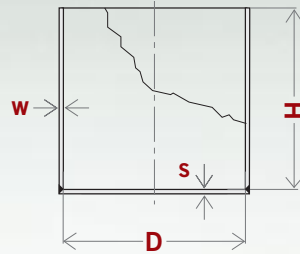

welded,
flat base

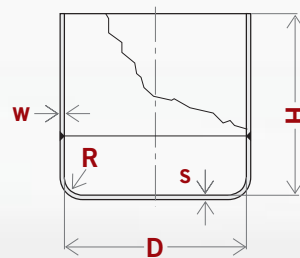

welded,
deep-drawn base

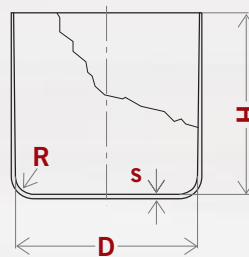

seamless



Special Products

Are precious metals necessary for your application requirements but you cannot find a suitable product in the available catalogues?

In that case you have found the right address with the Heraeus Precious Metals Technology.

We work with you on solutions for your problems. You describe your conditions – and we work out suggestions. Then we discuss the technical possibilities with you.

Our well trained specialists and our wide range of modern metal processing equipment ensure that we can manufacture precision parts to the closest tolerances.

The photographs on this page show you some of these components. We regret we are unable to show you the considerably more demanding products and hope you will understand that confidentiality agreements with our customers make this impossible.



Crucible and spindle



Metallic fluxes for gas analysis



Boiling chamber according to DIN 52 322, diam. 40 cm

Crucibles and rotating paddle



Seamless tubes with stiffening corrugation

Knudsen cells



The excellent resistance of platinum and the platinum group metals (Ir, Rh and Pd) to acids and oxidation at high temperatures, their high melting points and low vapour pressures make these metals indispensable materials for apparatus in the chemistry laboratory.

However, when using platinum equipment it must be remembered that even platinum is not a universal wonder material which is resistant to everything. For instance, damage can result from elements which form low-melting phases with platinum, from very aggressive chemical media or from evaporation.

Damage to platinum by tin, lead and bismuth

The formation of alloys with most metals leads to a reduction in the melting point of platinum, especially in the case of the low-melting metals tin, lead and bismuth. Thus, it is possible that even with low concentrations and at moderate temperatures the melting point can be exceeded in localised areas, which results in the destruction of the apparatus (see Table "Melting Temperatures of Low-Melting Precious Metal Alloys" on page 36).

It should be noted that, due to thermal decomposition and especially under reducing conditions, chemical compounds can dissociate and release these detrimental elements. Therefore, to avoid reduction, heating processes and ignitions should be carried out in oxidising atmospheres, i.e. in open crucibles. In this context it should be especially noted that hydrogen may be absorbed by platinum at 400° C, diffuse through the walls of equipment at higher temperatures and can reduce the material contained within.

Damage to platinum by carbon

Apart from reducing conditions in the environment, the presence of carbon or organic substances can also result in the reduction of chemical compounds and thus the release of elements which can damage platinum. Carbon itself can also cause damage to the structural integrity of platinum. Please take special care to adjust the flame when working with bunsen burners and ensure that gas-heated fusion equipment is adjusted to an oxygen-rich flame.

Handling Platinum Equipment

Phase diagram of the Pt-Si system

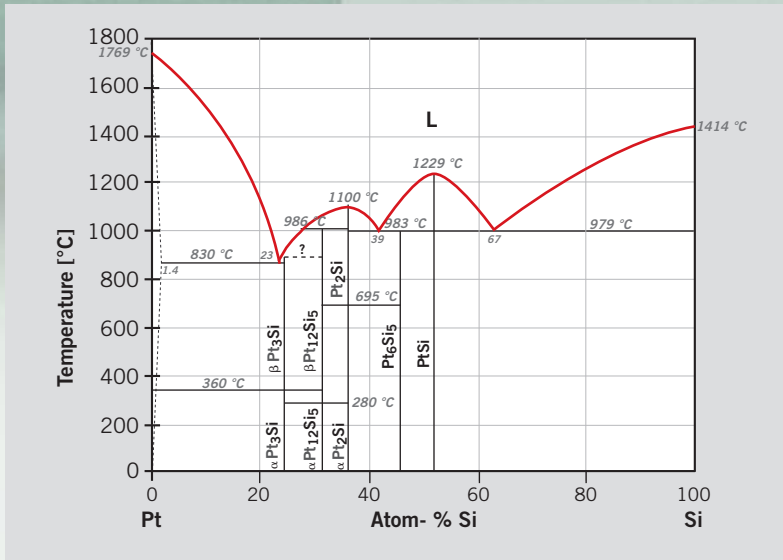

Damage to platinum by silicon, lead, antimony and phosphorus

A platinum alloy with a low melting point is formed when the elements silicon, antimony or arsenic are present in very small quantities. The alloy formation occurs preferentially at the grain boundaries. The embrittlement which is associated with this process can lead to the formation of cracks.

The effects are particularly hazardous when organic matter containing phosphorus is ignited, e.g. in flour ignition. Damage to apparatus by silicon corrosion can occur during heat treatment in furnaces with silicon carbide heating elements. Spalling of the exposed silicon carbide rods can lead to silicon being deposited on the platinum equipment or on the furnace floor which then diffuses into the platinum equipment.

Phase diagram of the Pt-As system

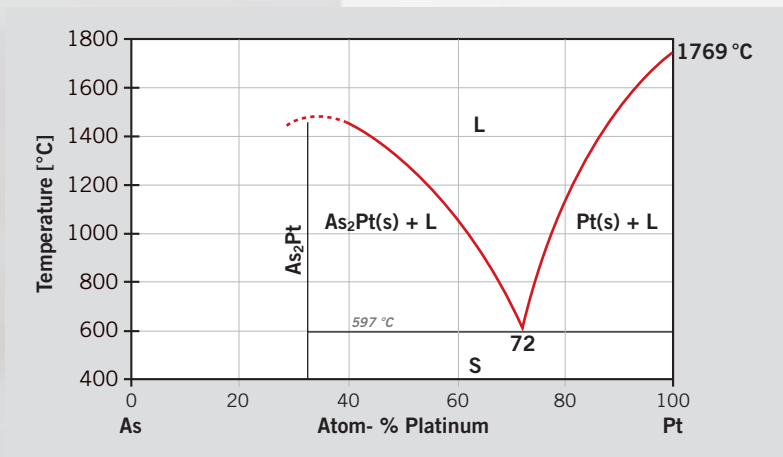

Damage to platinum by sulphur

Sulphur can also cause platinum corrosion. This problem is encountered, for example, when preparing fused tablets for XRF from samples containing high levels of sulphur in the form of sulphides.

Further potential hazards

A further potential hazard is contamination of the crucible on its external surface, for instance by placing it on a dirty surface. At elevated temperatures the contamination can then lead to one of the damage mechanisms described above. We recommend, therefore, that only crucible tongs or tweezers whose tips are protected with platinum should be used when handling hot crucibles. The crucible tongs must not be immersed into acids and alkalis beyond the platinum shoes, because of the danger that liquid could penetrate between the tongs and the shoe resulting in corrosion from within.

Naturally, care must also be taken that the triangles on which the laboratory equipment is usually heated are not contaminated by corrosive materials such as heavy-metal salts, phosphates, etc. Unprotected iron triangles or wire gauzes should not be used, but only those with platinum/iridium buttons, or those made of platinum wires. Alternatively non-precious metal wire triangles which are protected by oxide ceramic tubes at contact points may be used. Contact with ferrous materials should be generally avoided.

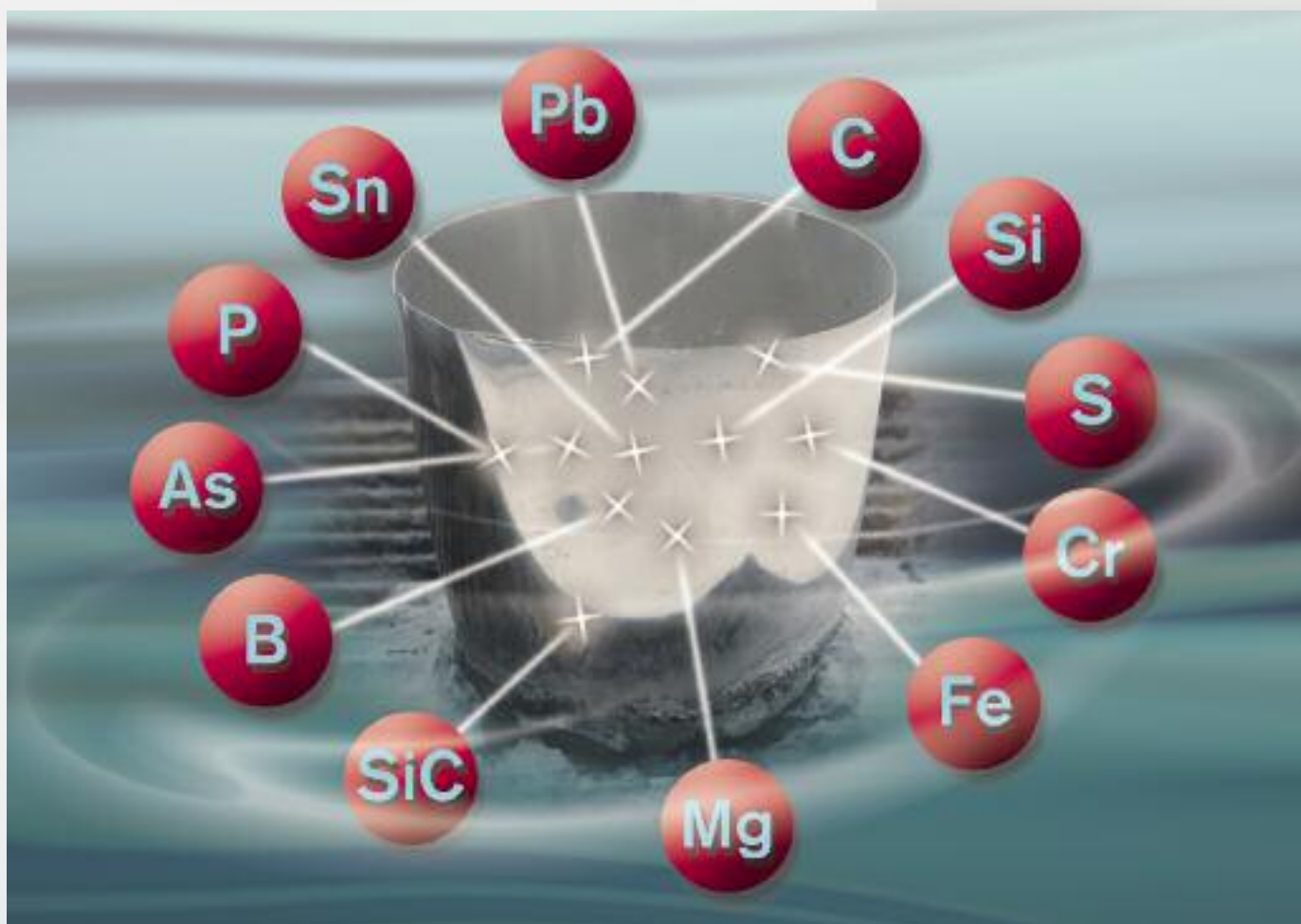

Handling Platinum Equipment

Heraeus has prepared a summary of the most important precautionary measures using actual case histories. ¹⁾

The phenomenon which is commonly known as "platinum corrosion" is not corrosion in the usual sense of aqueous corrosion, rusting, etc. It is usually the formation of a compound which results from a reaction of platinum with another element. It has a low melting point, and results in the formation of a eutectic with an even lower melting point between the compound and the platinum.

Petin et al.²⁾ describe an elegant procedure for carrying out a combined oxidation-fusion treatment:

1.25 g of the following low melting oxidation mixture is prepared: (60% NaNO_3 + 20% KNO_3 20% $\text{Sr}(\text{NO}_3)_2$) + 2 g Na_2CO_3 + 1.5 g $\text{Li}_2\text{B}_4\text{O}_7$ $\text{Li}_2\text{B}_4\text{O}_7$. The sample (250 mg) is mixed with this oxidation mixture and then added to the lithium tetraborate which is in the crucible. The oxidation mixture is composed in such a way that at the beginning of the fusion the components of the sample are encapsulated in a layer of molten salt before the nitrates decompose. In this way the platinum is protected from contact with the sample. The nitrates are selected so that they decompose over a broad temperature range starting with NaNO_3 at 380°C and continues up to $\text{Sr}(\text{NO}_3)_2$ at $> 1100^\circ\text{C}$, in order to ensure that the oxidation media do not completely decompose before the sample oxidises and dissolves in the lithium tetraborate.

Although the techniques described above are only necessary for strongly reducing samples, they clearly show that, with appropriate care, platinum crucibles can be used reliably for the fusion of a very broad variety of XRF samples.

The main precautionary measures

The main precautionary measures which must be observed when platinum equipment is used in an analytical laboratory are:

- Never place the crucible on an SiC support
- Take care to keep sufficient distance between the crucibles and SiC heating elements
- Ensure strongly oxidising conditions for samples containing carbon (ferro-alloys, carbides, etc.)
- Never touch the crucible with your bare hands
- Use Pt clad tongs
- Avoid mechanical damage of the crucibles
- Use separate crucibles for samples which are known to contain hazardous impurities (S, P, Pb, etc.)

The inner surface of the crucible is more difficult to protect especially when samples to be prepared contain both "poisons" and carbon. Examples are ferro-alloys (in particular ferro-silicon), carbides (in particular grinding media containing silicon carbide), active carbon, spent catalysts from oil refineries.

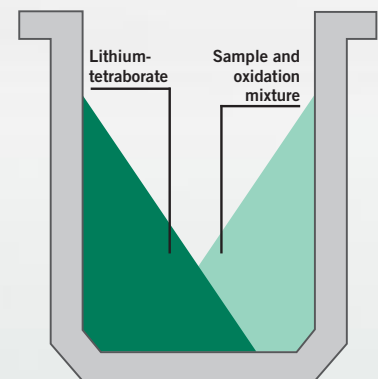

Charging a crucible for the fusion of ferro-alloy samples (Petin et al.²⁾)

Damage to platinum by salts, halogen compounds and acids

Less critical than the damage mechanisms described above is corrosion due to salts, halogen compounds or acids. Normally the advantages of using platinum crucibles are greater than the risk of damage by corrosion. At room temperature platinum only dissolves slowly in aqua regia.

Amongst the most severe effects are the melting of alkali metal hydroxides and alkali cyanides at high temperatures. Potassium compounds react more strongly than sodium compounds in such fusion preparations. Alkalis have the effect of being oxygen carriers and oxidise platinum to yellow-brown platinum oxide.

For this reason molten salt preparations, above all in soda and soda-potash fusions, should always be carried out in covered crucibles. In this way the carbon dioxide released during the fusion can be retained as a protective gas over the melt and prevents the crucible from oxidation.

Evaporation losses

It is not always appreciated that a thin oxide film forms on platinum in air at room temperature and evaporates at elevated temperatures. The platinum loss which occurs as a result can lead to significant damage over very long operating periods, e.g. at 900°C in air. This effect can be counteracted to a limited extent by alloying with a few percent of rhodium. Platinum-iridium alloys with higher iridium contents, on the other hand, suffer from evaporation losses which are very much greater than for other platinum alloys when exposed to air for long periods. ³⁾

Cleaning crucibles

Crucibles and dishes of platinum or platinum alloys are cleaned by boiling in a suitable solvent. Platinum utensils can be cleaned very thoroughly by melting potassium pyrophosphate in them. For the removal of substances which have alloyed with the surface we recommend that the apparatus be scoured with alumina powder.

The use of grinding media containing carbon (e.g. SiC) should be avoided at all costs. Any remaining alumina residues should be removed with a hydrofluoric acid treatment. Contaminated utensils may not, under any circumstances, be cleaned by heating, because the impurities might thereby diffuse into the platinum.

Treatment of electrodes

The dissolution of electrolytically deposited metal layers from platinum electrodes is achieved with analytically pure acids. Burning off gauze electrodes over an open flame is not to be recommended because of the risk that impurities remain embedded in the corners and that these then form an alloy. Furthermore this heating causes an undesirable softening of the wire gauze and thus reduces its resistance to deformation. Clean electrodes should be stored in a desiccator.

The stability of the remaining metals of the platinum group (Ir, Rh, Pd, Os, Ru) in aggressive media is shown in the Table "Stability of the Platinum Group Metals in Corrosive Media" on page 37.

Should problems arise in the course of using platinum equipment or should the solution to a specific problem be required, we are pleased to be at your service with further information.

- 1) J. Merker, F. Schölz, D. F. Lupton: "Correct Use of Platinum in the XRF Laboratory", "Tricks of the Trade" at the 19th Durham Conference on X-ray Analysis, University of Durham, England, 18 – 21 September 1995
- 2) J. Petin, A. Wagner and F. Bentz "Combination of Oxidation and Melt Treatment for a Rapid Preparation of Metallic and Other Oxidising Samples for X-ray Fluorescence Analysis", *Steel Research*, 56 (1985), 215-218
- 3) H. Jehn: "High Temperature Behaviour of Pt-Group Metals in Oxidizing Atmospheres", *Journal of the Less Common Metals*, 100 (1984), 321

Physical and Chemical Properties

Melting temperatures [°C] of low melting precious metal alloys

Alloys	Pt	Pd	Au	Ag	Rh	Ir
B	825	743	1050	961	1131	1046
Si	830	798	370	835	1389	1470
P	588	788	935	878	1245	1262
As	597	–	665	540	–	–
Sn	1070	–	278	221	–	–
Sb	633	590	360	485	610	–
Pb	290	265	213	304	–	–
Bi	730	–	241	262	–	–
S	1240	623	–	742	925	–



Material	Melting Point Melting Range [°C]	Density [g/cm ³]	Linear expansion coefficient (20–100°C) 10 ⁻⁶ [K ⁻¹]	Electrical resistivity (annealed) bei 20°C [Ω • mm ² • m ⁻¹]	Temperature coefficient of electrical resistivity (0–100°C) 10 ⁻⁴ [K ⁻¹]
Pt	1769	21.45	9.1	0.107	39.0
Ir	2447	22.65	6.8	0.049	43.0
Pd	1554	12.02	11.1	0.099	38.0
Rh	1963	12.41	8.3	0.043	46.0
Os	3050	22.61	6.1	0.096	42.0
Ru	2315	12.20	9.1	0.073	46.0
Au	1063	19.32	14.1	0.027	40.0
Ag	961	10.49	18.7	0.016	41.0
PtRh 10	1840–1870	20.00	10.0	0.200	16.3
PtRh 20	1870–1910	18.10	9.3	0.208	13.4
PtIr 10	1780–1800	21.60	8.6	0.250	12.0
PtIr 20	1830–1855	21.70	7.7	0.310	7.5
PtAu 5	1675–1745	21.32	–	0.180	21.0

Resistance of the Platinum Group Metals to Corrosive Media

corrosive medium	Chemical formula	Temperature [°C]	Pt	Pd	Au	Ag	Rh	Ir
Aluminum sulphate	Al ₂ (SO ₄) ₃	100	1	1	1	1	1	–
Bromine, dry	Br ₂	20	3	4	1	1	1	4
Bromine, moist	Br ₂	20	3	4	1	1	1	2
Bromine water		20	1	2	1	1	1	–
Hydrobromic acid	HBr	20	2	4	2	1	1	1
Hydrobromic acid	HBr	100	4	4	3	1	1	3
Chloride, dry	Cl ₂	20	2	3	1	1	1	1
Chloride, moist	Cl ₂	20	2	4	1	1	1	3
Acetic acid, glacial	CH ₃ COOH	100	1	1	1	1	1	–
Fluorine	F ₂	20	2	–	–	–	–	–
Hydrofluoric acid 40 %	HF	20	1	1	1	1	1	1
Iodine, dry	I ₂	20	1	4	1	1	1	2
Iodine, moist	I ₂	20	1	2	2	1	1	1
Hydroiodic acid	HI	20	1	4	1	1	1	2
Potassium hydroxide	KOH	400	3	2	2	–	4	4
Potassium cyanide	KCN	20	1	3	–	–	–	–
Potassium cyanide	KCN	100	3	4	–	–	–	–
Potassium bisulphate	KHSO ₄	500	1	2	3	1	–	–
Aqua regia	HNO ₃ + 3 HCl	20	4	4	1	1	1	4
Aqua regia	HNO ₃ + 3 HCl	100	4	4	1	2	1	4
Copper chloride	CuCl ₂	100	1	2	–	–	–	–
Copper sulphate	CuSO ₄	100	1	1	1	1	1	–
Sodium hypochlorite	NaClO	20	1	3	2	2	4	4
Sodium hydroxide	NaOH	500	2	2	2	–	4	4
Ortho-phosphoric acid	H ₃ PO ₄	100	1	2	1	1	1	4
Mercuric chloride	HgCl ₂	100	1	1	1	1	3	–
Nitrit acid 95 %	HNO ₃	100	1	4	1	1	1	4
Sulphurite acid 36 %	HCl	20	1	1	1	1	1	1
Sulphurite acid 65 %	HCl	20	1	4	1	1	1	3
Sulphurite acid 65 %	HCl	100	2	4	1	1	1	4
Hydrochloric Acid 96 %	H ₂ SO ₄	20	1	1	1	1	1	1
Hydrochloric Acid 96 %	H ₂ SO ₄	100	1	3	2	1	1	1
Hydrochloric Acid 96 %	H ₂ SO ₄	300	2	4	3	–	–	–
Hydrogen sulphide	H ₂ S	20	1	1	1	1	1	1
Selenic acid	H ₂ SeO ₄	20	1	3	–	–	–	–
Selenic acid	H ₂ SeO ₄	100	3	4	–	–	–	–
Hydrogen peroxide	H ₂ O ₂	100	4	–	–	–	–	–

1 = no corrosion 2 = slight corrosion 3 = noticeable corrosion 4 = destructive corrosion

The values given in the table are guidelines and cannot be guaranteed for specific applications.

	Thermal conductivity at 20°C [Wm ⁻¹ K ⁻¹]	Yield point		Tensile strength		Tensile elongation		Vickers hardness		Young's modulus [GPa]
		[MPa]		[MPa]		[%]				
		annealed	hard	annealed	hard	annealed	hard	annealed	hard	
	74	70	290	150	330	40	3.0	42	98	170
	59	93	–	450	–	7	–	210	453	528
	75	65	400	180	480	35	3.0	40	210	121
	88	68	–	800	1925	9	–	410	410	380
	87	–	–	–	–	–	–	350	1000	570
	105	38	–	500	–	3	–	240	750	430
	312	50	260	180	300	40	3.0	40	90	78
	419	120	320	140	380	37	3.0	35	110	80
	30	180	670	300	680	32	1.5	102	204	255
	–	110	920	380	940	32	2.0	113	273	268
	31	220	630	340	650	32	2.0	105	215	220
	–	380	920	570	940	21	2.0	190	300	230
	–	370	610	460	635	7	1.0	139	194	180

Weitere physikalische Daten: Landolt Börnstein, 1996, IV. Band, Teil 2, Springer Verlag

Material Properties and Possible Applications

of Precious Metals and Alloys

The alloys listed in the table below represent only a small selection of the alloys produced by Heraeus. We will be pleased to help you with your inquiries or special requirements.

Werkstoff	Melting point or range [° C]	Material properties	Possible applications
Pt	1769	High thermal and chemical stability. Platinum in various purities.	Laboratory apparatuses such as crucibles and dishes which are only exposed to low mechanical stresses
Pt-DPH PtAu 95/5-DPH PtRh 90/10-DPH	1769 1675–1745 1840–1870	The finely dispersed oxide particles in platinum and platinum alloys significantly increase the mechanical strength and corrosion resistance.	Laboratory equipment and structural components which are subject to high mechanical stresses at high temperatures.  Ask for our DPH brochure
PtIr 97/3 PtIr 90/10 PtIr 80/20	1772–1773 1780–1800 1830–1855	The mechanical strength, thermal and corrosion resistance become greater with increasing iridium content. Platinum-iridium alloys suffer from increased weight loss in oxidising atmosphere.	Laboratory apparatuses or structural components which are exposed to severe mechanical, thermal and corrosive effects.
PtRh 90/10 PtRh 80/20	1840–1870 1870–1910	The mechanical strength, thermal and corrosion resistance become greater with increasing rhodium content. An advantage of the platinum-rhodium alloys is that only a minimal weight loss occurs even in oxidising atmosphere.	Heavy-duty laboratory equipment, electrodes, glass fibre bushings and lining materials for components to contain molten glass.
Platilab 11®		Small quantities of platinum group metals have been added to high purity platinum, in order to obtain a finer crystal structure for better chemical and mechanical characteristics.	Laboratory apparatuses or structural components which are exposed to severe mechanical, thermal and corrosive effects.
PtAu 95/5	1675–1745	The gold content reduces the wetting by glass melts so that the glass can be easily removed after solidification without leaving any residues. The mechanical strength is also increased and the tendency to recrystallisation reduced.	These properties predestine PtAu 95/5 as the material for apparatus for the preparation of samples for X-ray fluorescence analysis (XRF).
AuPt 90/10	1120–1180	This gold alloy shows increased mechanical strength compared with pure gold and good resistance to phosphorus. Platinum based alloys are more susceptible to corrosion by phosphorus.	Dishes, e.g. for flour ignition, sugar ignition, etc.
Ag Au	961 1063	Good conductivity, chemical stability (in particular, resistant to phosphorus).	Crucibles for reagents which corrode platinum alloys; contact materials.
Ir	2447	Iridium is the preferred material for oxide melts because of its good corrosion resistance and high temperature stability in inert atmospheres.	Crucibles for crystal growing. Components which are subject to severe thermal conditions.



W. C. Heraeus GmbH

Engineered Materials Division

Business Unit Precious Metals Technology

Heraeusstr. 12 – 14

63450 Hanau, Germany

Phone + 49 61 81.35 37 40

Fax + 49 61 81.35 86 20

E-mail: precious-metals-technology@heraeus.com

www.wc-heraeus.com/precious-metals-technology

www.pt-labware.com